

# Rosa Pools

THE SWIMMING POOL HANDBOOK



# Index

	Pg.
<b>Introduction</b>	03
<b>Unique Pools</b>	05
Collections	06
Systems	16
Solutions	42
<b>Sport Pools</b>	47
Collections	50
Systems	56
Solutions	78
Accessories	84
<b>Technical information</b>	86





## Unique solutions for unique pools

Over 40 years of experience in the pool industry and thousands of projects throughout the world are the keys to our specialization: **manufacturing porcelain stoneware solutions to facilitate the design and construction of swimming pools, from beginning to end.**

**Complete solutions** are essential since they support the entire creation and construction process: design and architecture, as well as choosing the most appropriate construction system and the perfect placement product.

**Solutions for offering an excellent service.** Thanks to our technical advisory team, which is specialized in advising architects; and our online resources, with the new collection of **BIM objects** now available.

**Innovative solutions,** such as our porcelain grids, available in over 30 colors and which won a 2016 Architizer Award; and our **exclusive anti-slip finishes**, comfortable and easy to clean.

**Flexible and practical solutions** that can be applied to any kind of swimming pool project: for competitions, sports, hotels, Wellness areas, public or private.

**Design solutions.** Diversity of colors, textures, formats and a specific range of pieces designed specifically for swimming pools.

**Constructive solutions.** **System 9** for coping and **System 10** for facilitating the overall construction of the pool tank.

Designing solutions is a fascinating mission. It involves discovering, innovating and improving. With this new catalog, **Rosa Pools**, our goal is not only diverse but also unique and exciting: **for our solutions to provide the best help when carrying out your projects.**



Private pool, Spain  
Siela Grey & Pietro Dark



# Unique Pools

**COLOURS AND SOLUTIONS FOR POOLS DESIGN**

**HOTEL - WELLNESS - FITNESS CLUB - PRIVATE RESIDENCE**

## trésor



**Trésor Bali**



**Trésor Java**

## stela *MIX*



**Stela White**



**Stela Golden**



**Stela Grey**



**Stela Dark**

## pietro *MIX*



**Pietro White**



**Pietro Golden**



**Pietro Grey**



**Pietro Dark**

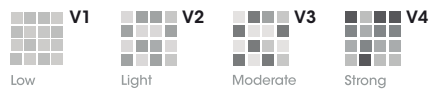

SHADE VARIATIONS

RECOMMENDED GROUT JOINTS BY ROSA GRES

**Eurocolor Flex**

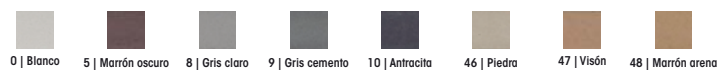

**Cerpoxi / Professional PX**



**alma**



**Alma Mist**



**Alma Forest**



**Alma Honey**



**Alma Pure**

**serena**



**Serena Bianco**



**Serena Ocre**



**Serena Griggio**



**Serena Nero**



**Serena Mix \***

\* Available in 31 x 62,6 x 0,9

**mistry**



**Mistry White**



**Mistry Sand**



**Mistry Grey**



**Mistry Blue Stone**



Private Pool  
Trésor Java & Serena Bianco



### ANTI-SLIP

UNE 41091	DIN 51130	DIN 51097	ANSI A137.1
 CLASE 3	 R10	 CLASE C	> 0.42

 316  
anti-slip  
31 x 62,6 x 0,9



**Trésor Bali**

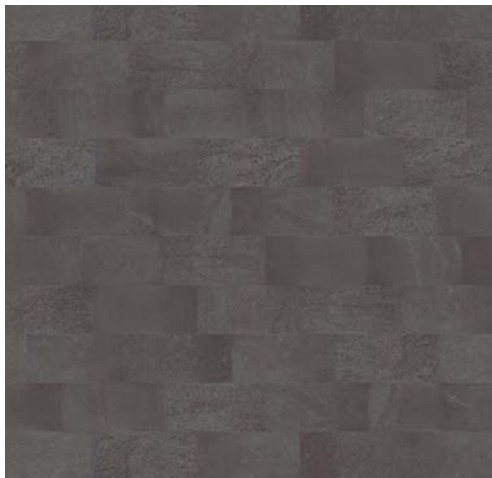

**Trésor Java**



Private pool  
Trésor Bali & Stela White

### ANTI-SLIP

UNE 41091	DIN 51130	DIN 51097	ANSI A137.1
CLASE 3	R11	CLASE C	> 0.42

### SMOOTH

UNE 41091	DIN 51130	ANSI A137.1
CLASE 1	R9	> 0.42

199  
smooth / anti-slip  
19,4 x 97,9 x 1



**Stela White**



**Stela Golden**



**Stela Grey**



**Stela Dark**



Private pool  
Stela Golden & Pietro Golden



Private pool  
Stela White, Stela Golden & Pietro Golden



Private pool  
Stela Dark & Pietro Dark

ANTI-SLIP

UNE 41091	DIN 51130	DIN 51097	ANSI A137.1
CLASE 3	R11	CLASE C	> 0.42

	<b>316</b> anti-slip 31 x 62,6 x 0,9		<b>50M</b> anti-slip 48,8 x 97,9 x 1		<b>490</b> anti-slip 48,8 x 48,8 x 1
--	--	--	--	--	--



Pietro White



Pietro Golden



Pietro Grey



Pietro Dark



Private pool  
Pietro White



Private pool  
Pietro Golden



Private pool  
Pietro Golden & Pietro Dark

### ANTI-SLIP

UNE 41091	DIN 51130	DIN 51097	ANSI A137.1
			
CLASE 3	R11	CLASE C	> 0.42

	<b>316</b> anti-slip 31 x 62,6 x 0,9		<b>490</b> anti-slip 48,8 x 48,8 x 1
---	--	---	--

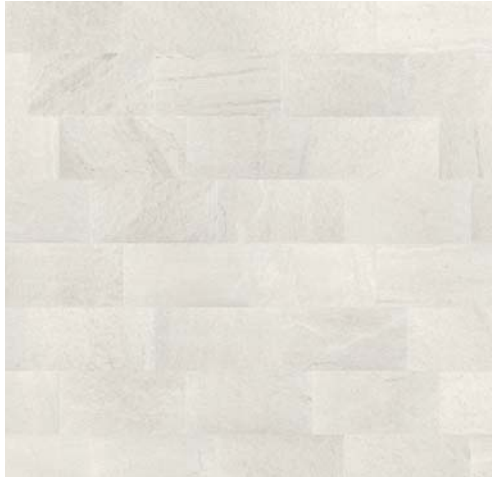

**Serena Bianco**



**Serena Odra**



**Serena Griggio**



**Serena Nero**



Private pool  
Serena Bianco



Private pool  
Serena Odra



Private pool  
Serena Griggio



## Serena Mix

Ref. 316 only (31 x 62,6 x 0,9)



Private pool  
Serena Mix



Private pool, France  
Serena Mix & Serena Griggio

### ANTI-SLIP

UNE 41091	DIN 51130	DIN 51097	ANSI A137.1
CLASE 3	R11	CLASE C	> 0.42

### SMOOTH

UNE 41091	DIN 51130	ANSI A137.1
CLASE 1	R9	> 0.42



**316**  
smooth / anti-slip  
31 x 62,6 x 0,9



**50M**  
smooth / anti-slip  
48,8 x 97,9 x 1



**Mistery White**



**Mistery Sand**



**Mistery Grey**



**Mistery Blue Stone**



Private pool | Josep Aurell, GAAB Arquitectes | EUSA-AWARDS PRIZE 2019  
Mistery White



Hotel Balneari Vichy Catalán, Caldes de Malavella, Spain | Sander Cornelius Laudy Architect  
Mistery Sand

## ANTI-SLIP

UNE 41091	DIN 51130	DIN 51097	ANSI A137.1
CLASE 3	R11	CLASE C	> 0.42

## SMOOTH

UNE 41091	DIN 51130	ANSI A137.1
CLASE 1	R9	> 0.42

199  
smooth / anti-slip  
19,4 x 97,9 x 1



Alma Pure



Alma Honey



Alma Forest



Alma Mist



Private pool  
Alma Forest



Private pool  
Alma Pure



Private pool  
Alma Mist

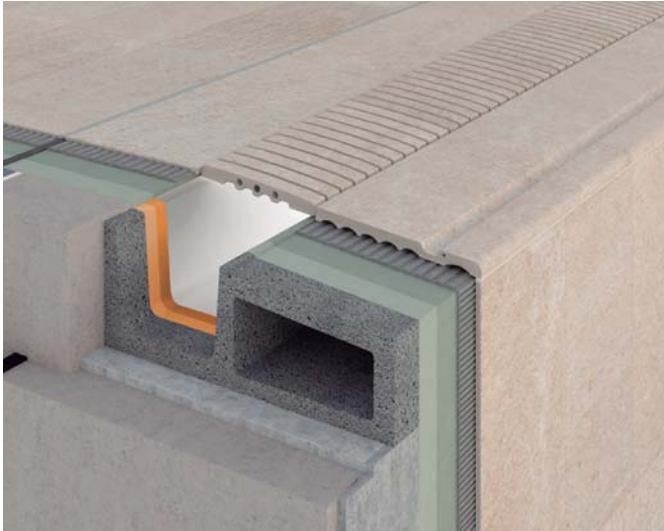

**Prestige**

DECK LEVEL POOL SYSTEM



**Smart**

OVERFLOW POOL SYSTEM



**Slim**

OVERFLOW POOL SYSTEM

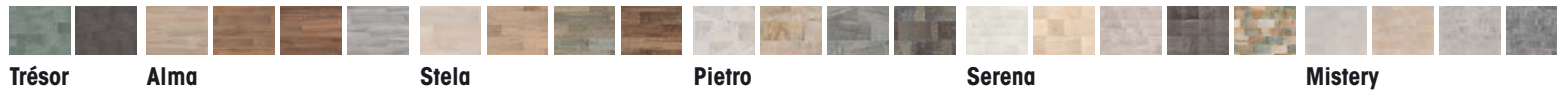

Trésor

Alma

Stela

Pietro

Serena

Mystery



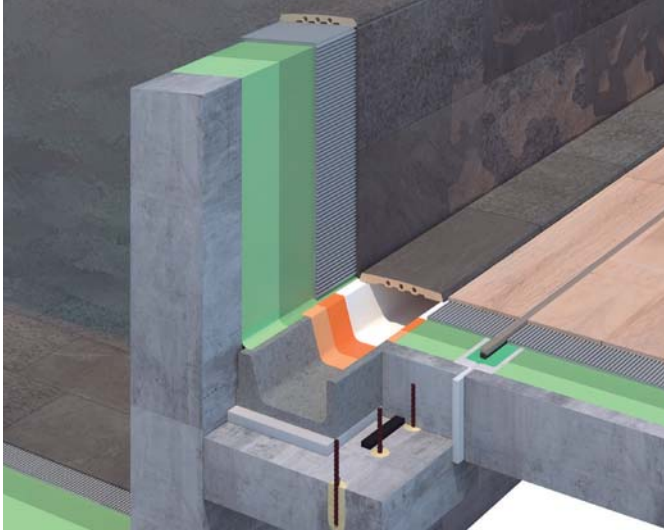

**Zen System**

INFINITY SYSTEM



**Infinity Solution**

INFINITY SYSTEM

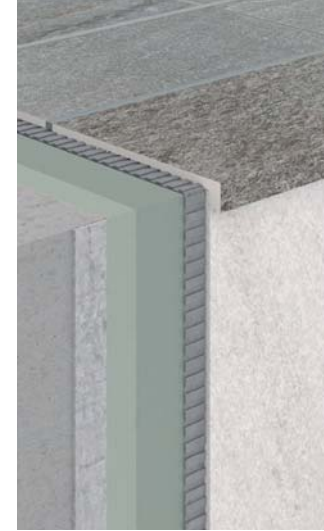

**Skimmer L**

SKIMMER SYSTEM



**Skimmer S**

SKIMMER SYSTEM

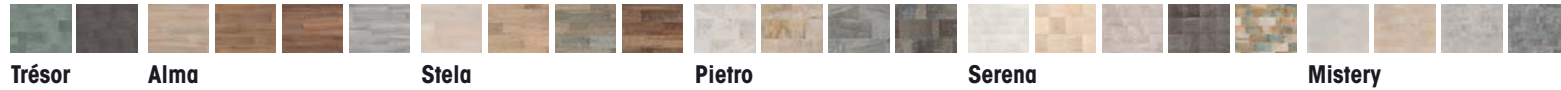

## Prestige

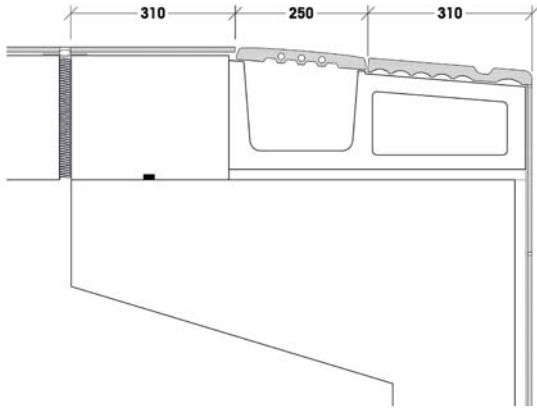

A downward-sloping pre-deck system comprised of a single 31 x 62.6 piece. S9 blocks provide the slope and support the overflow grate.

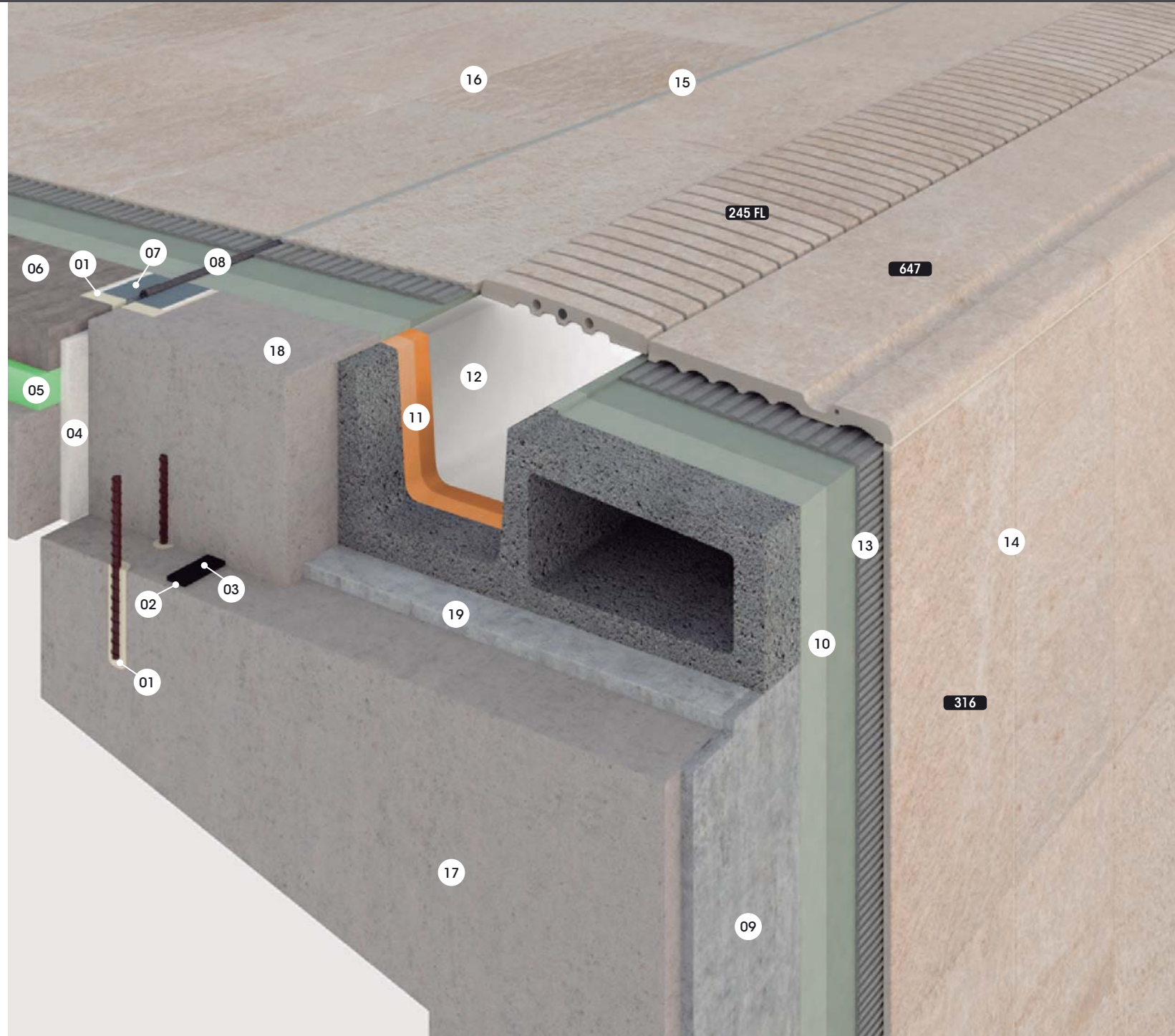

- 01 EPOXICOL
- 02 MASTIC MS
- 03 FUGA-STOP MINI 20 x 10 mm
- 04 Expanded polystyrene
- 05 Extruded polystyrene
- 06 PAVIFORT
- 07 FIX-TAPE 170 mm
- 08 SELLALASTIC FOAM
- 09 FIX-REVOCO
- 10 HIDROELASTIC
- 11 HIDROFIX
- 12 EPOXICOLOR
- 13 TECNOCOL FLEX
- 14 CERPOXI
- 15 SELLALASTIC
- 16 EUROCOLOR FLEX
- 17 Concrete structure of the tank
- 18 Wall behind the Rosa Gres S9 blocks
- 19 Improved adhesive mortar with Primfix to fix S9 pieces

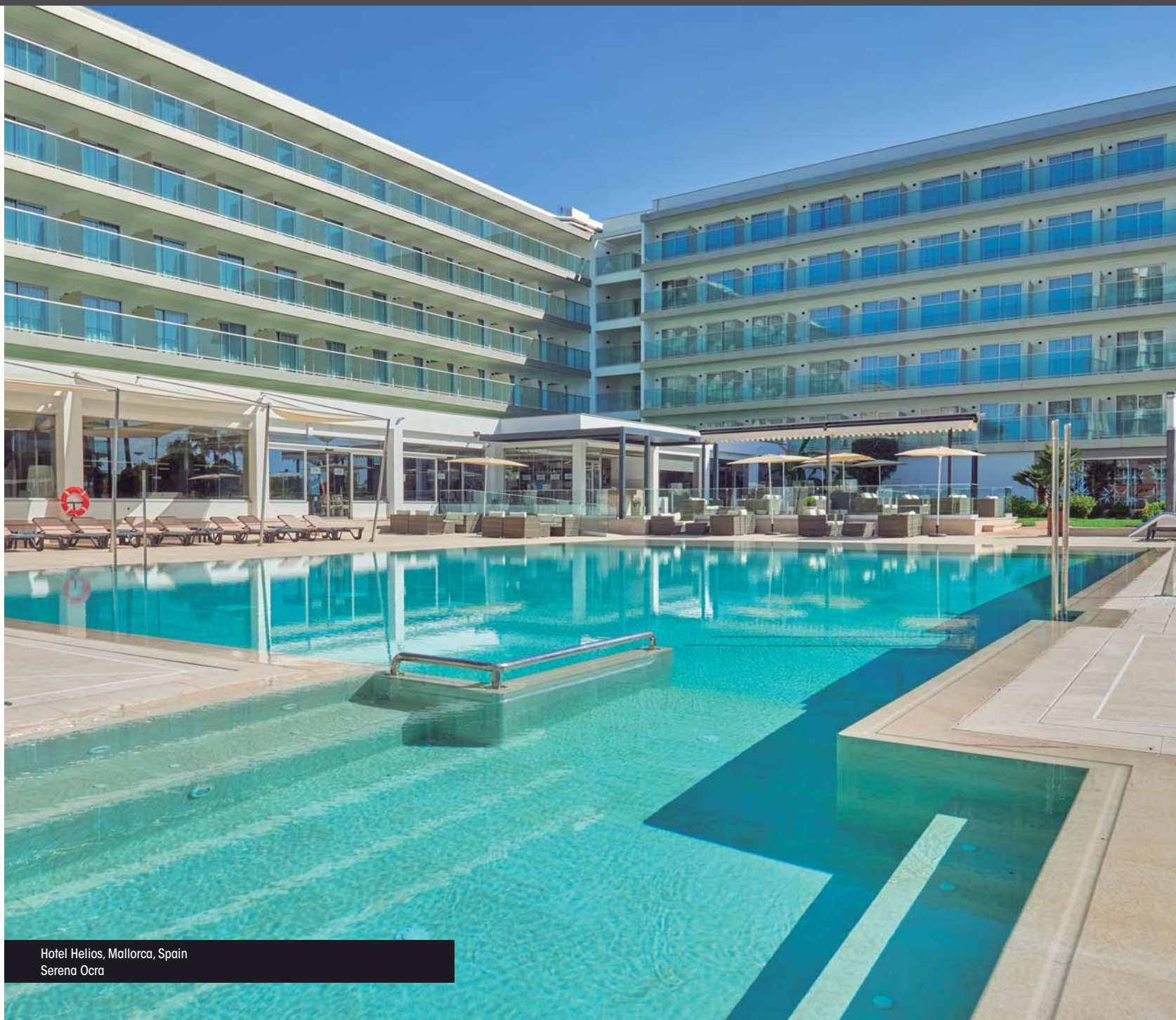

Hotel Helios, Mallorca, Spain  
Serena Ocra

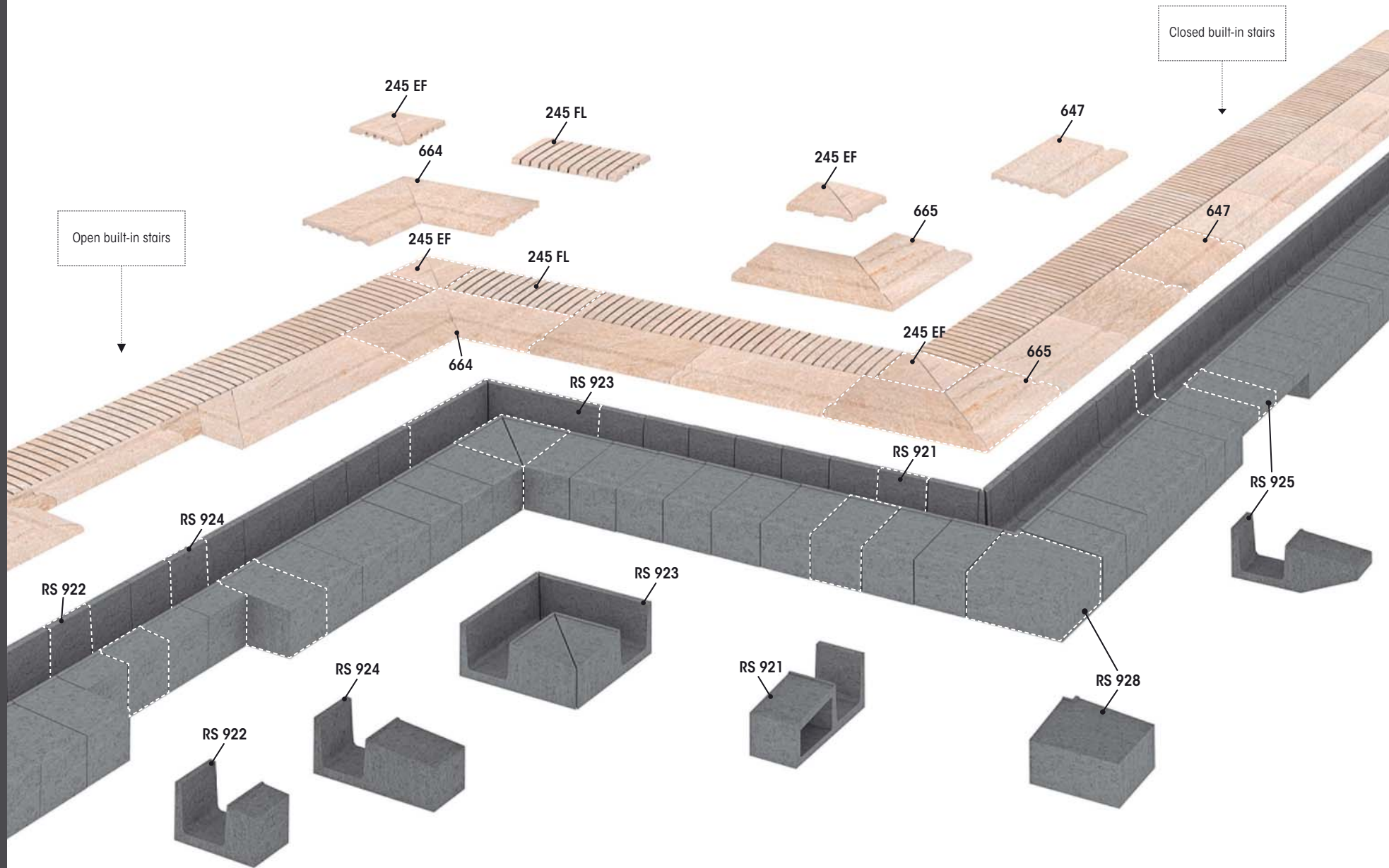

Coping tiles and corners

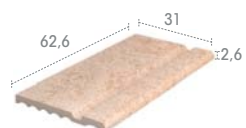

**647**  
anti-slip

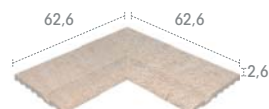

**664**  
anti-slip



**665**  
anti-slip

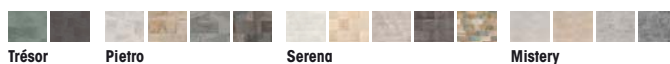

Trésor

Pietro

Serena

Mistery

S9 Blocks

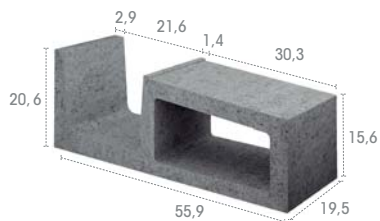

**RS 921**  
Base

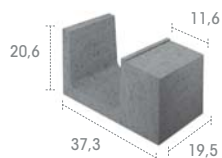

**RS 922**  
Open built-in stairs

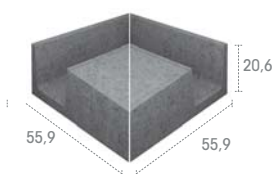

**RS 923**  
Inside corner



**RS 924**  
Solid

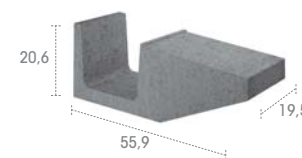

**RS 925**  
Closed built-in stairs



**RS 928**  
Outside corner

## Smart

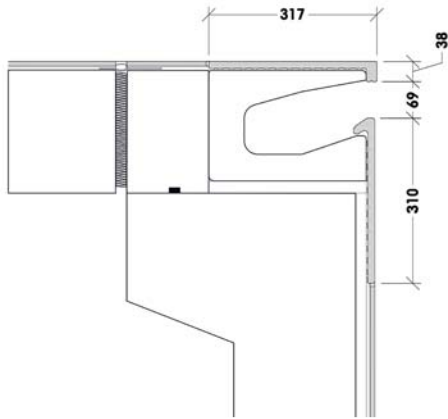

It is a hidden longitudinal overflow system that makes it possible to keep the water level below the deck level. This way, it stops the water from spilling out of the pool. Thanks to its design, swimmers can also grip onto it.

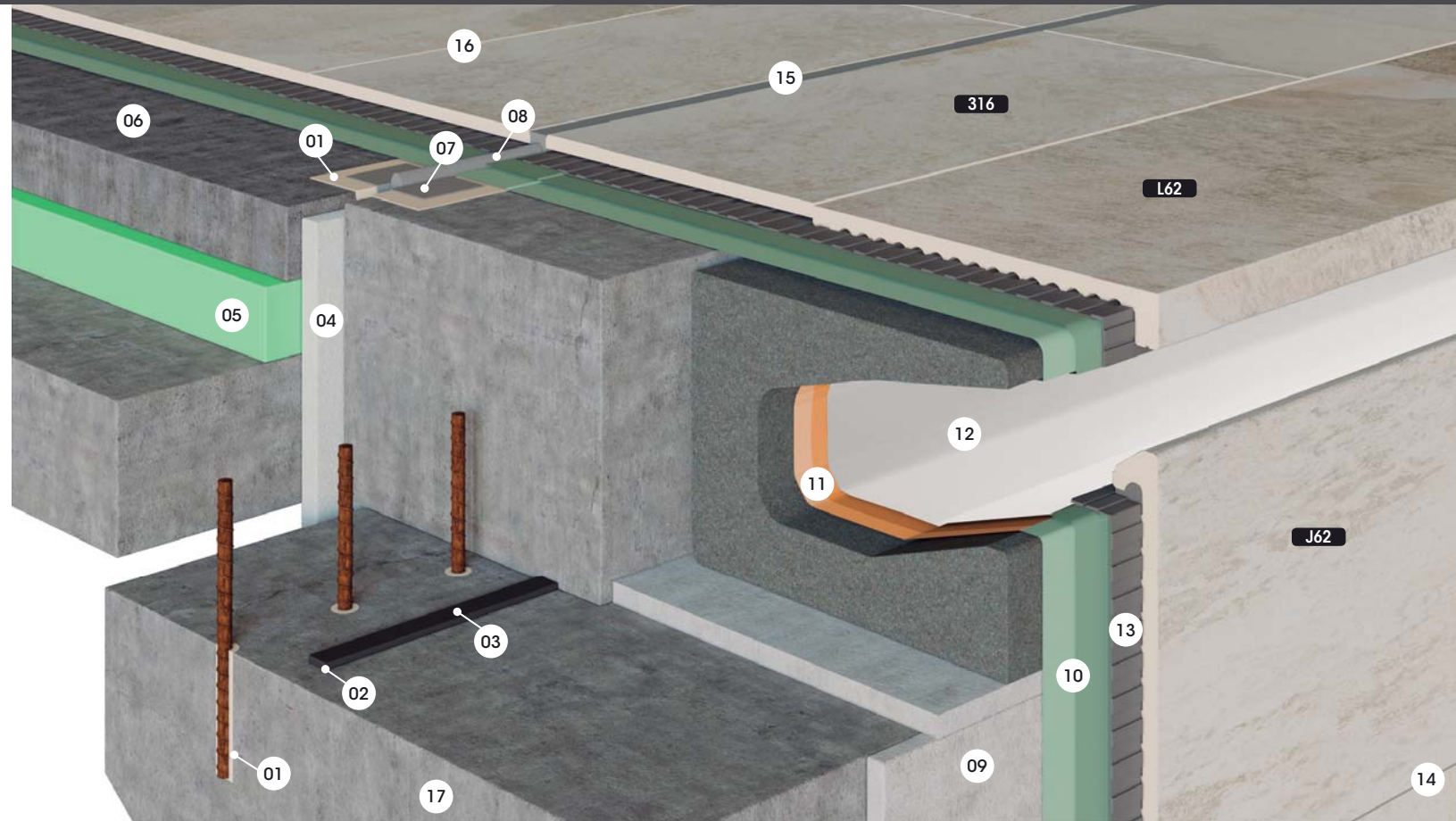

01 EPOXICOL

02 MASTIC MS

03 FUGA-STOP MINI 20 x 10 mm

04 Expanded polystyrene

05 Extruded polystyrene

06 PAVIFORT

07 FIX-TAPE 170 mm

08 SELLALASTIC FOAM

09 FIX-REVOCO

10 HIDROELASTIC

11 HIDROFIX

12 EPOXICOLOR

13 TECNOCOL FLEX

14 CERPOXI

15 SELLALASTIC

16 EUROCOLOR FLEX

17 Concrete structure of the tank



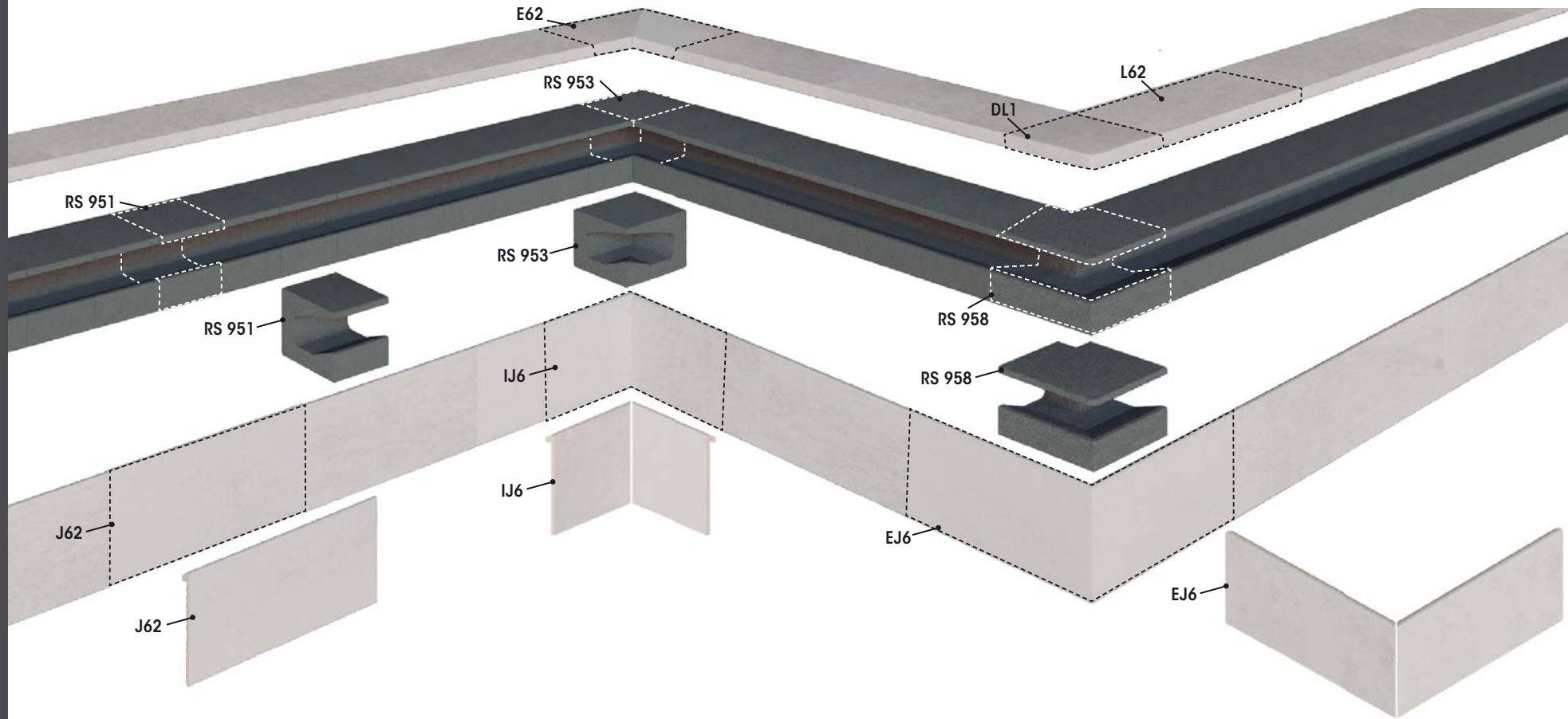



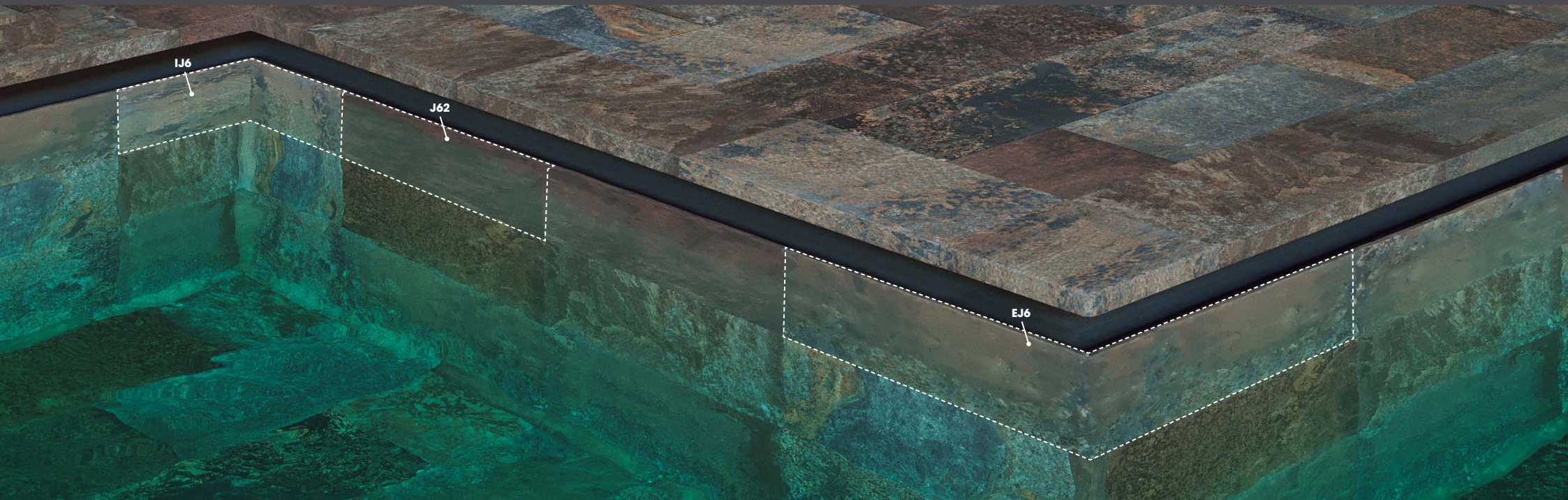

Coping tiles and corners

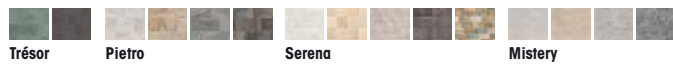

S9 Blocks

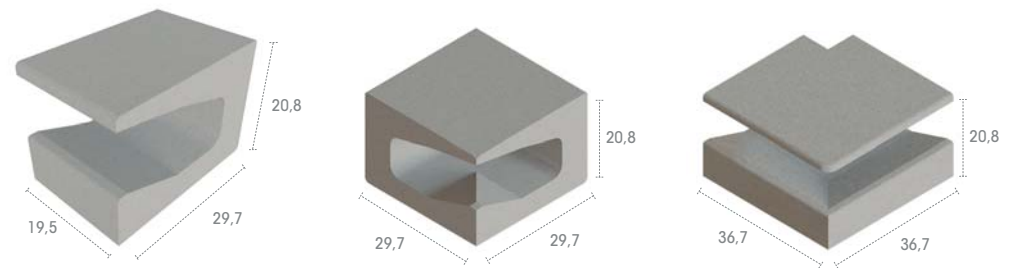

**RS 951**

Base

**RS 953**

Inside corner

**RS 958**

Outside corner

## Slim

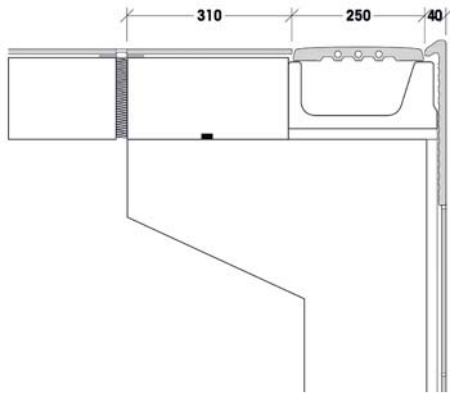

The Slim System innovation is a practical and functional solution for overflow pool projects with limited deck space. The design places the water level above that of the deck, creating an attractive mirror effect.

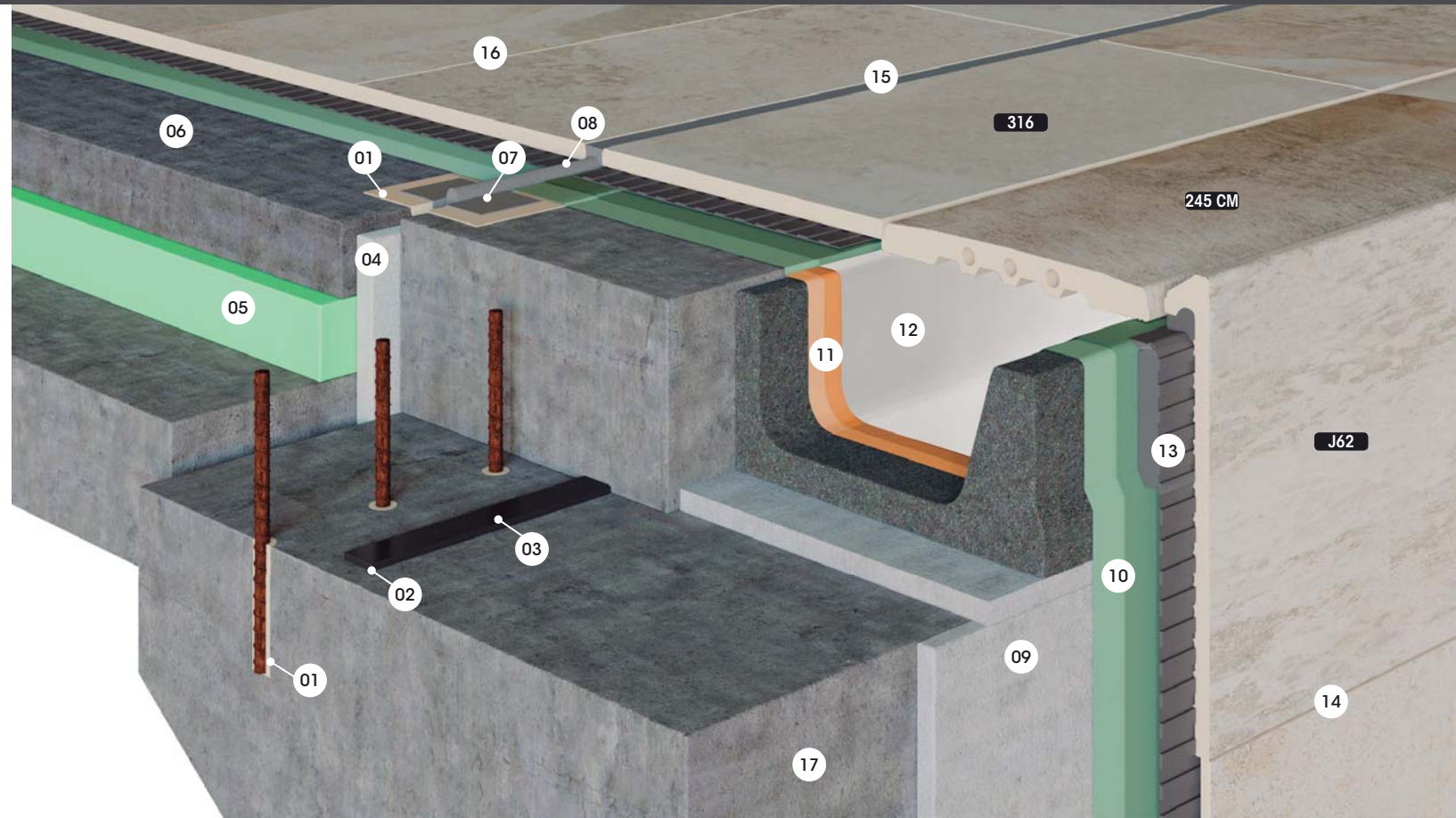

01 EPOXICOL

02 MASTIC MS

03 FUGA-STOP MINI 20 x 10 mm

04 Expanded polystyrene

05 Extruded polystyrene

06 PAVIFORT

07 FIX-TAPE 170 mm

08 SELLALASTIC FOAM

09 FIX-REVOCO

10 HIDROELASTIC

11 HIDROFIX

12 EPOXICOLOR

13 TECNOCOL FLEX

14 CERPOXI

15 SELLALASTIC

16 EUROCOLOR FLEX

17 Concrete structure of the tank



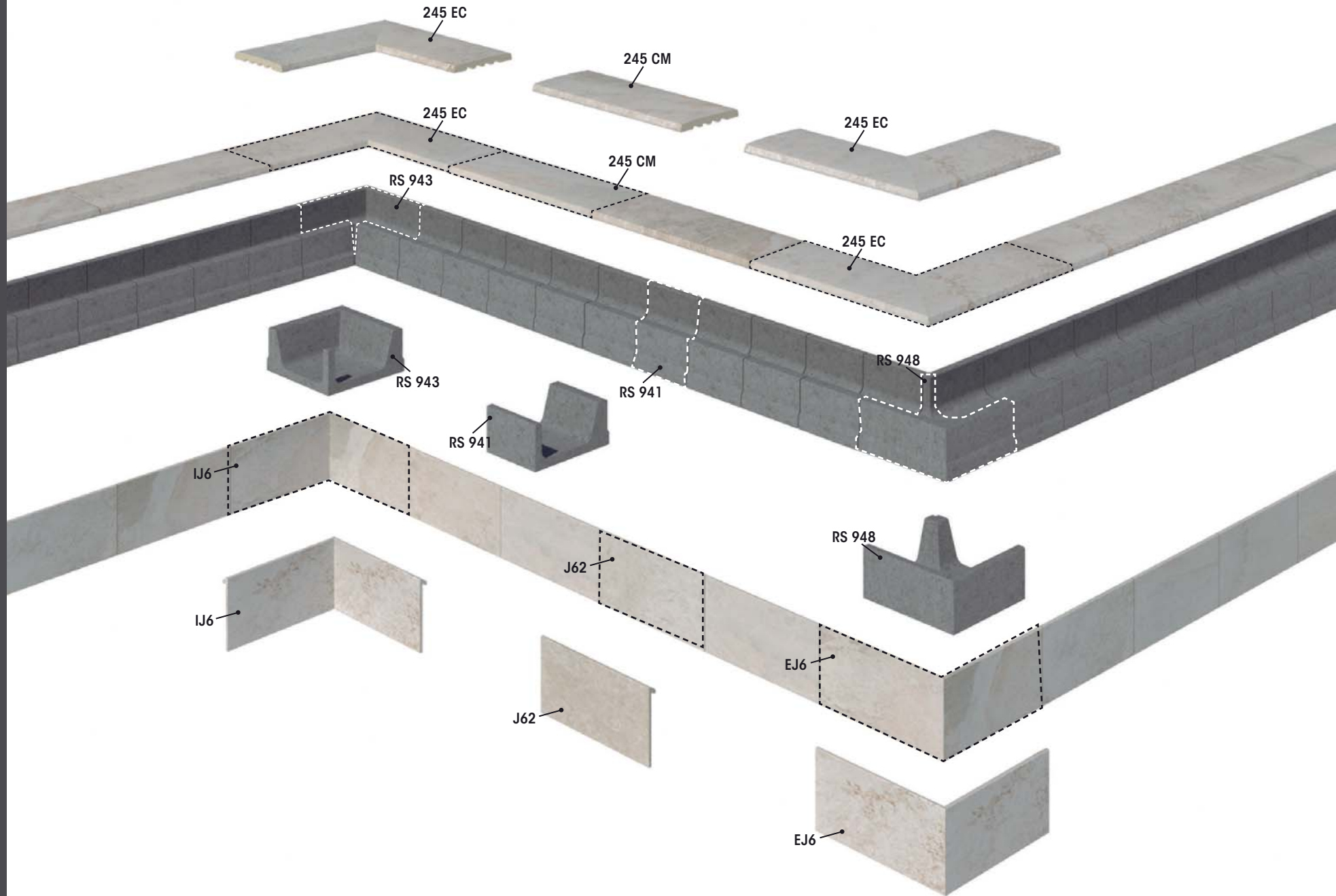

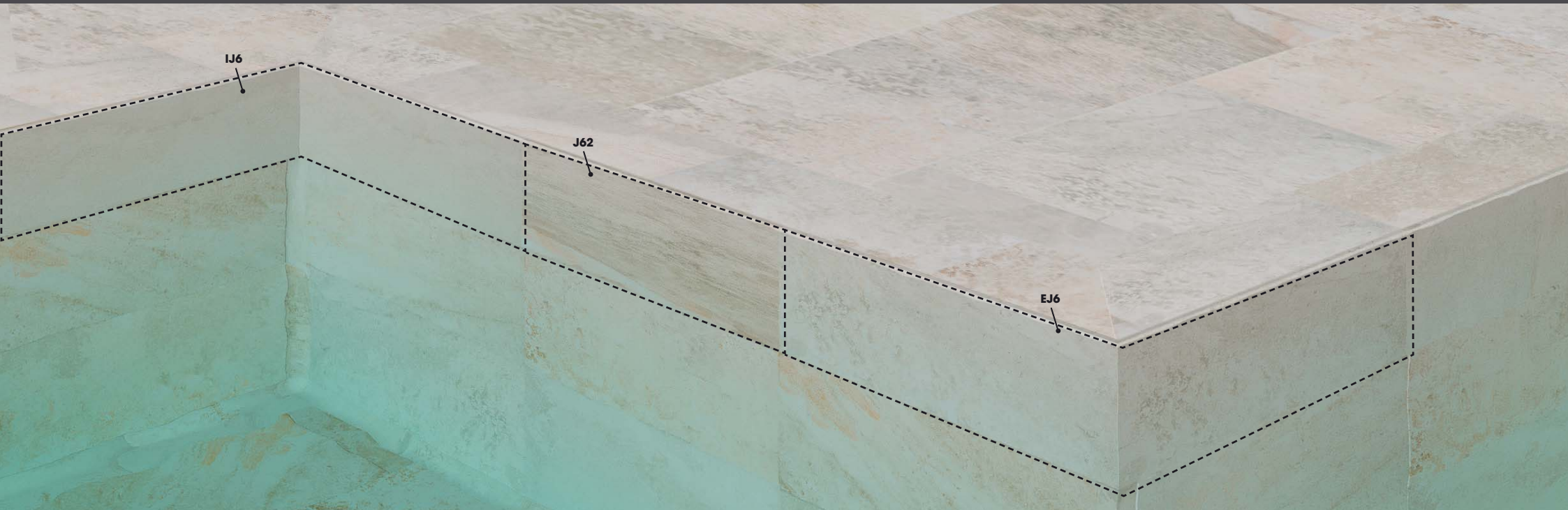

Coping tiles and corners



**J62**  
anti-slip

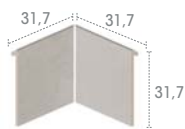

**IJ6**  
anti-slip



**EJ6**  
anti-slip

S9 Blocks

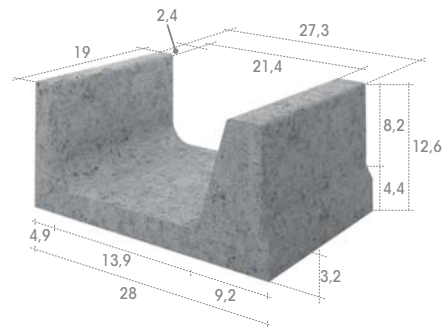

**RS 941**

Base

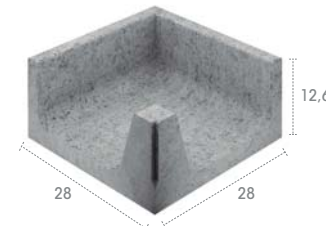

**RS 943**

Inside corner

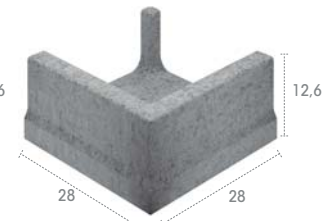

**RS 948**

Outside corner



## Zen System

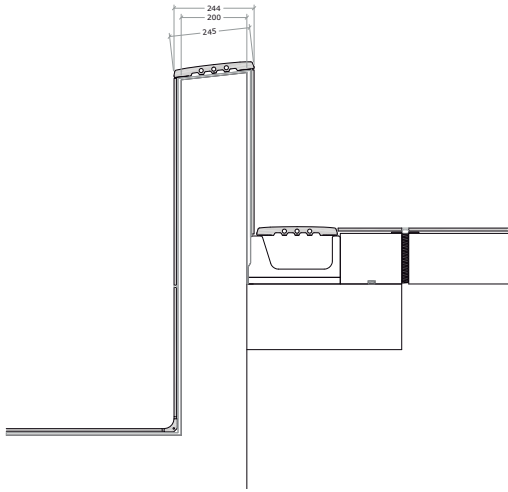

Perimeter overflow above ground pool with an invisible channel integrated into the decking.

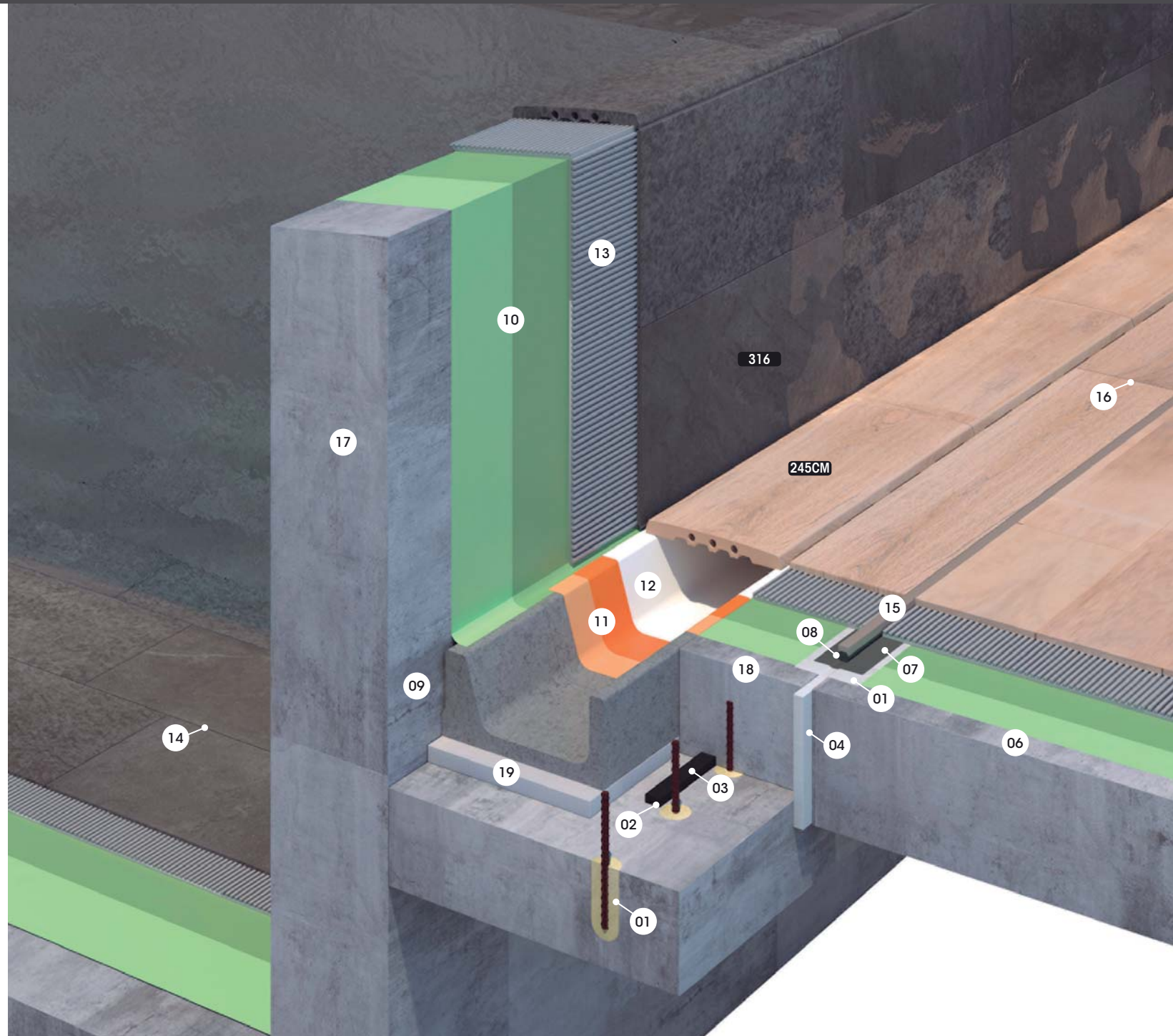

- 01 EPOXICOL
- 02 MASTIC MS
- 03 FUGA-STOP MINI 20 x 10 mm
- 04 Expanded polystyrene
- 06 PAVIFORT
- 07 FIX-TAPE 170 mm
- 08 SELLALASTIC FOAM
- 09 FIX-REVOCO
- 10 HIDROELASTIC
- 11 HIDROFIX
- 12 EPOXICOLOR
- 13 TECNOCOL FLEX
- 14 CERPOXI
- 15 SELLALASTIC
- 16 EUROCOLOR FLEX
- 17 Concrete structure of the tank
- 18 Wall behind the Rosa Gres S9 blocks
- 19 Improved adhesive mortar with Primfix to fix S9 pieces



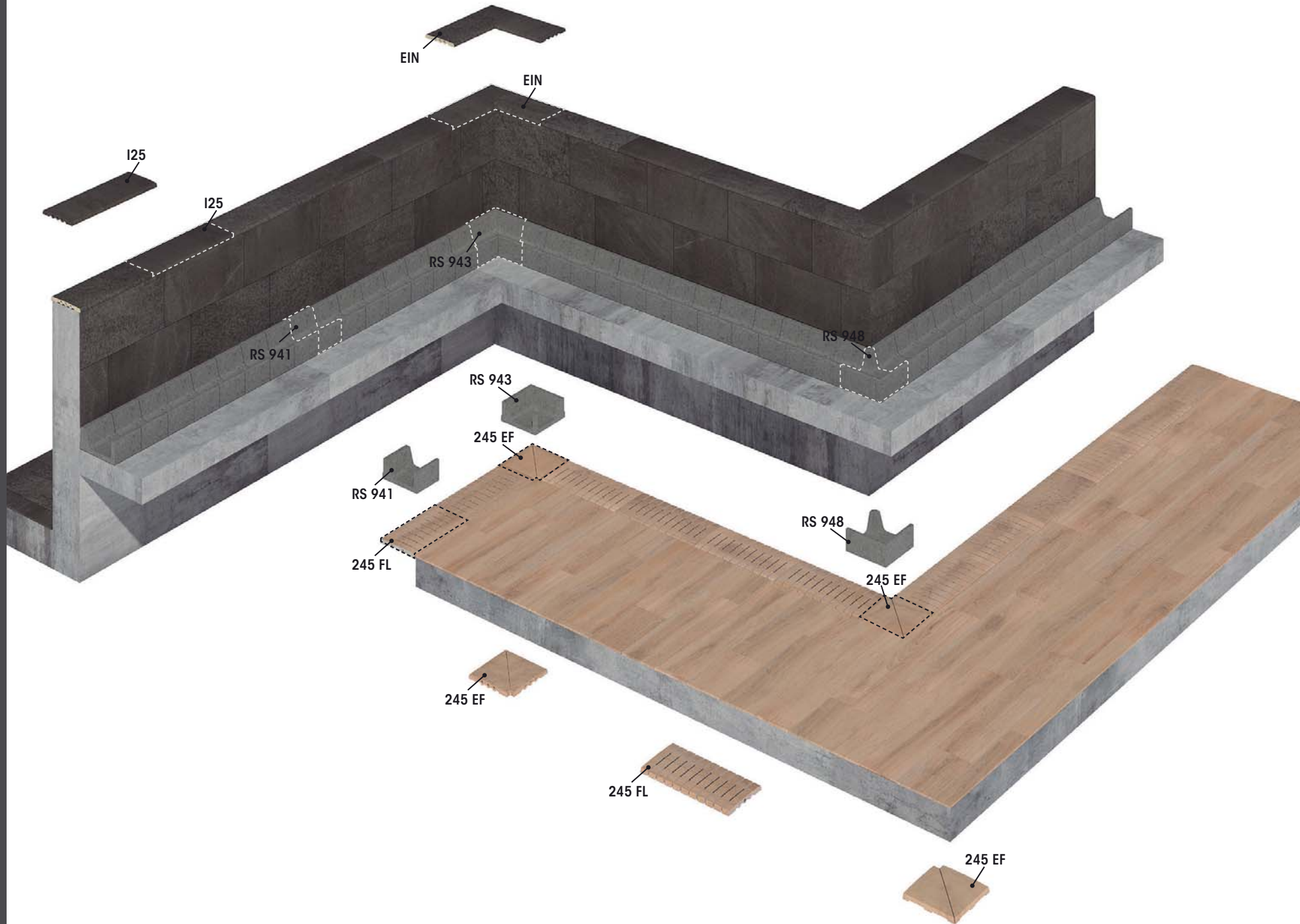



Coping tiles and corners

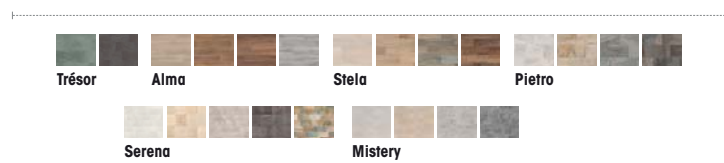
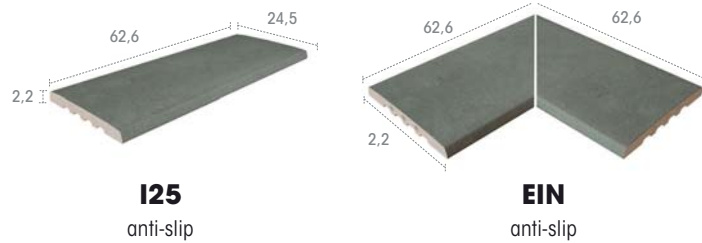

S9 Blocks

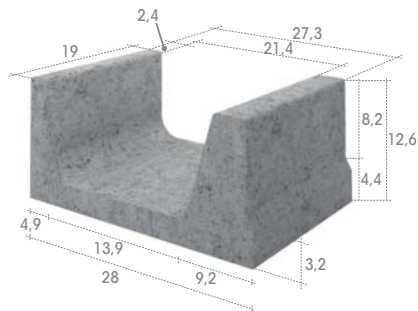

**RS 941**

Base

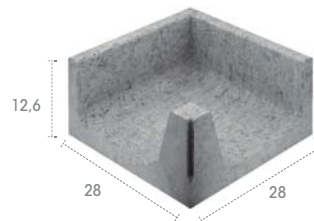

**RS 943**

Inside corner

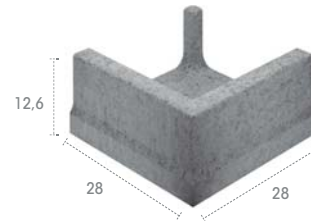

**RS 948**

Outside corner

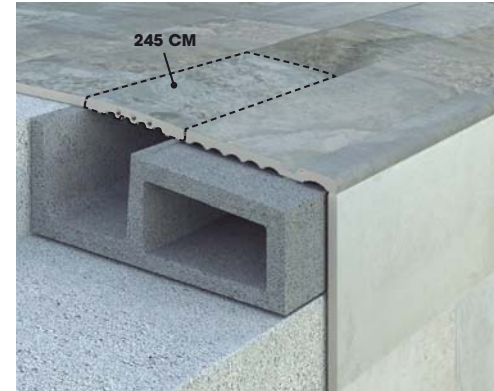

**245 CM**



Allows a correct water runoff.

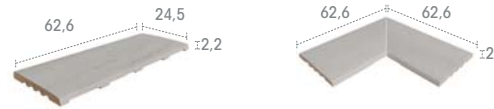

**245 CM**  
anti-slip

**245 EC**  
anti-slip

It consists in one unique piece created without adhesives. Once in place it integrates completely with the edge of the pool. The water is drained through lateral openings that are barely visible and have optimum capacity.



**Trésor**



**Alma**



**Stela**



**Pietro**



**Serena**



**Mystery**

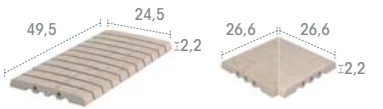
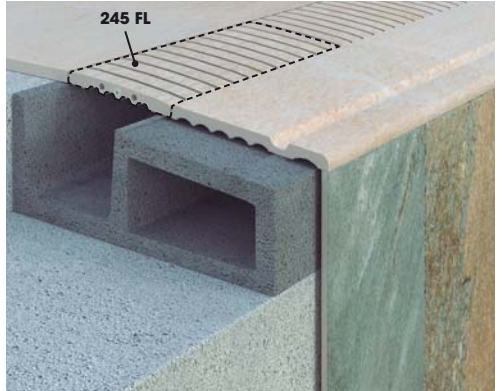

**245 FL**  
anti-slip

**245 EF**  
anti-slip



Its trapezoid-shaped structure allows for perfect water flow even when it is badly placed. It makes repositioning loose pieces easier.

It can be used to create curves with a radius of more than 75 cm.

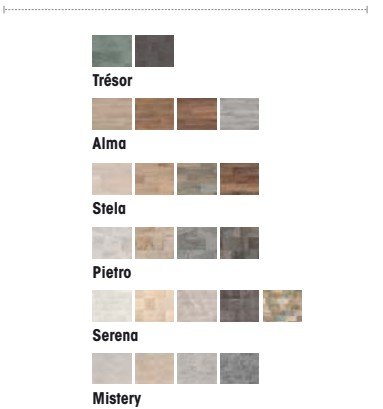



Private pool  
Mistry Blue Stone

## Coping tiles

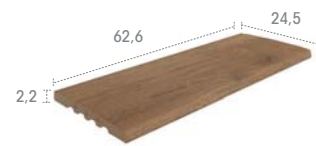
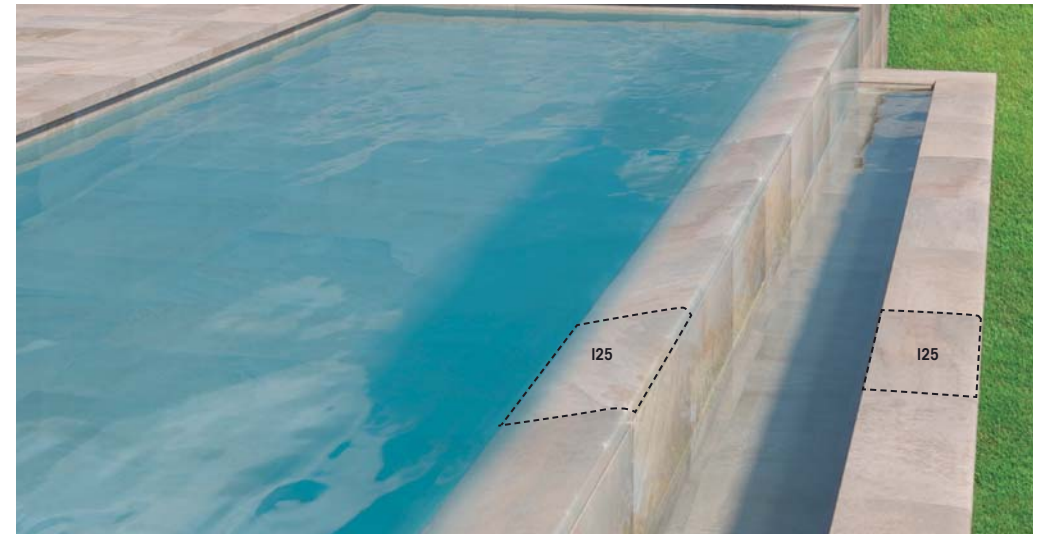
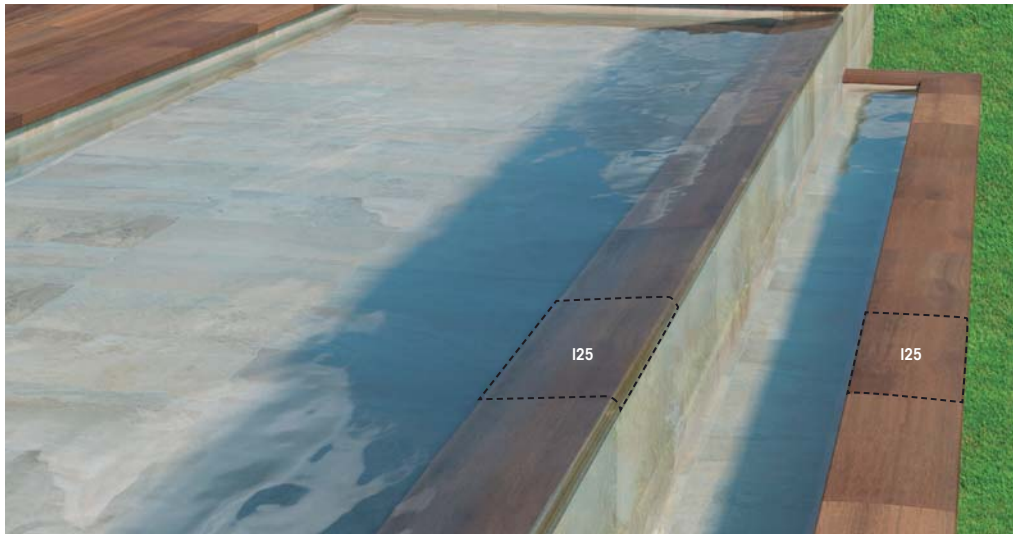

**I25**  
anti-slip



**EIN**  
anti-slip



Most private swimming pools are built with this system. The water level lies about 20 cm below the pool rim; the pool water is filtered through an opening or skimmer.

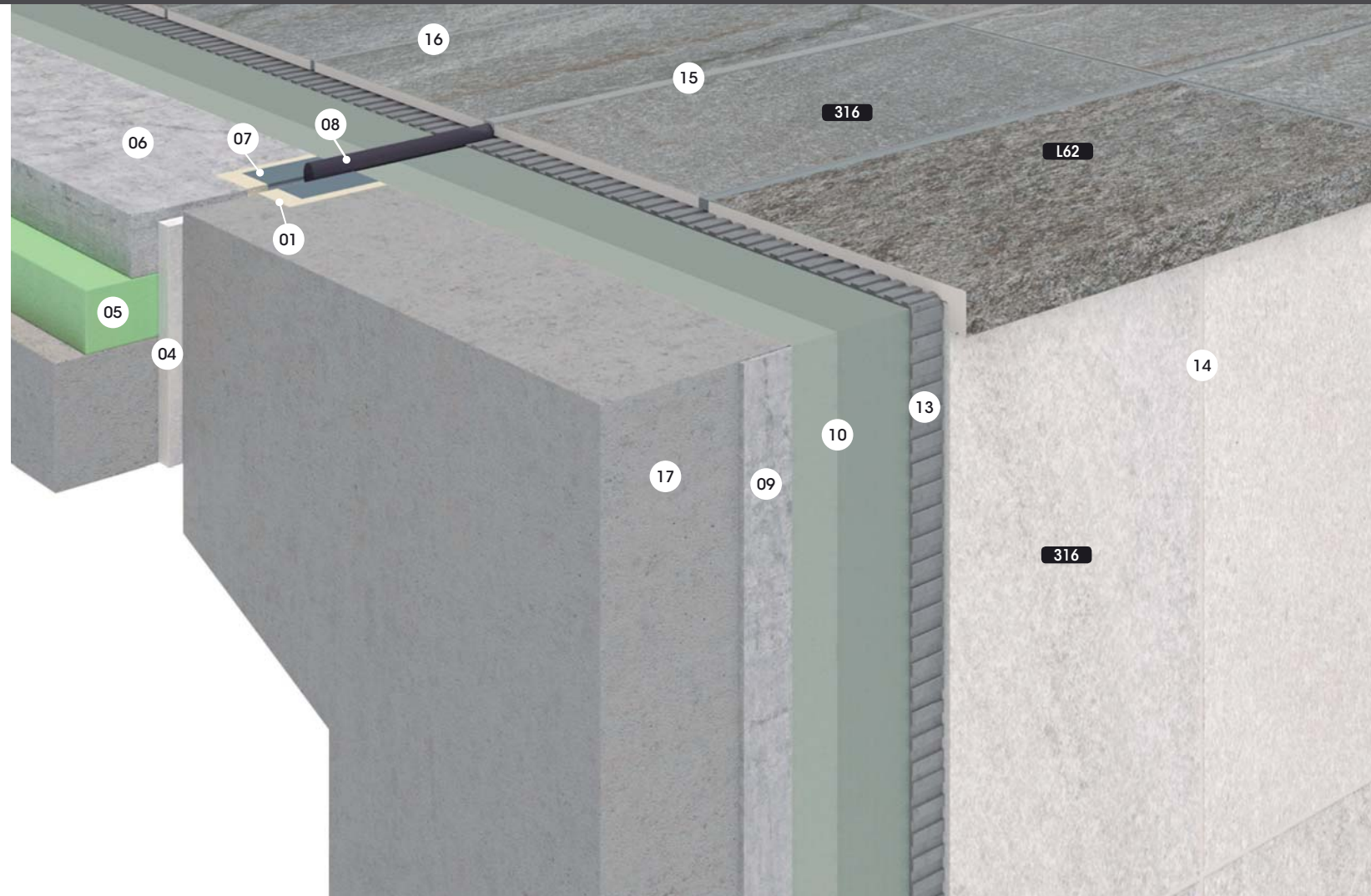

01 EPOXICOL

04 Expanded polystyrene

05 Extruded polystyrene

06 PAVIFORT

07 FIX-TAPE 170 mm

08 SELLALASTIC FOAM

09 FIX-REVOCO

10 HIDROELASTIC

13 TECNOCOL FLEX

14 CERPOXI

15 SELLALASTIC

16 EUROCOLOR FLEX

17 Concrete structure of the tank

Coping tiles

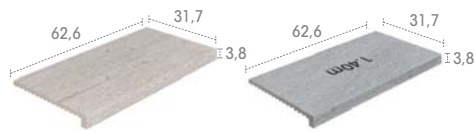
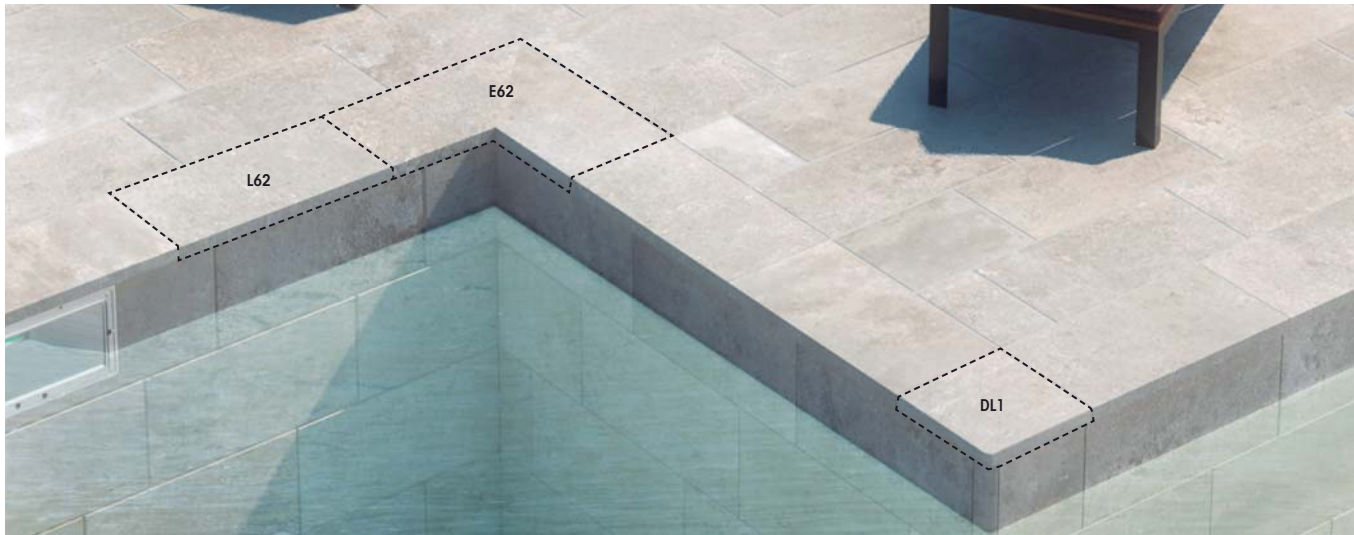

**L62**  
anti-slip

**L62 NU**  
anti-slip



**L98**  
anti-slip

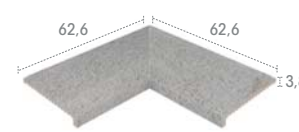

**E62**  
anti-slip

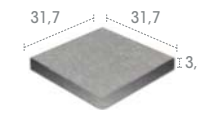

**DL1**  
anti-slip

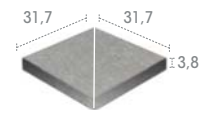

**DL2**  
anti-slip

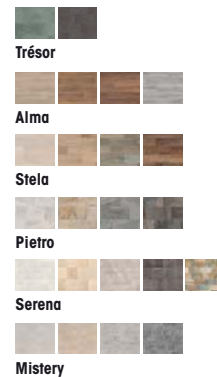
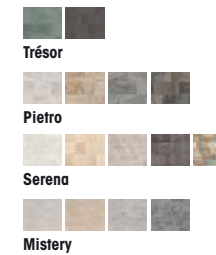
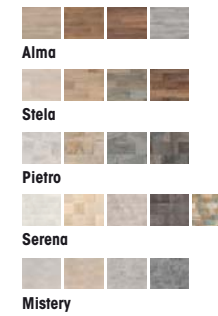
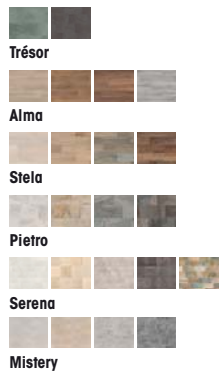

Most private swimming pools are built with this system. The water level lies about 20 cm below the pool edge; the pool water is filtered through an opening or skimmer.

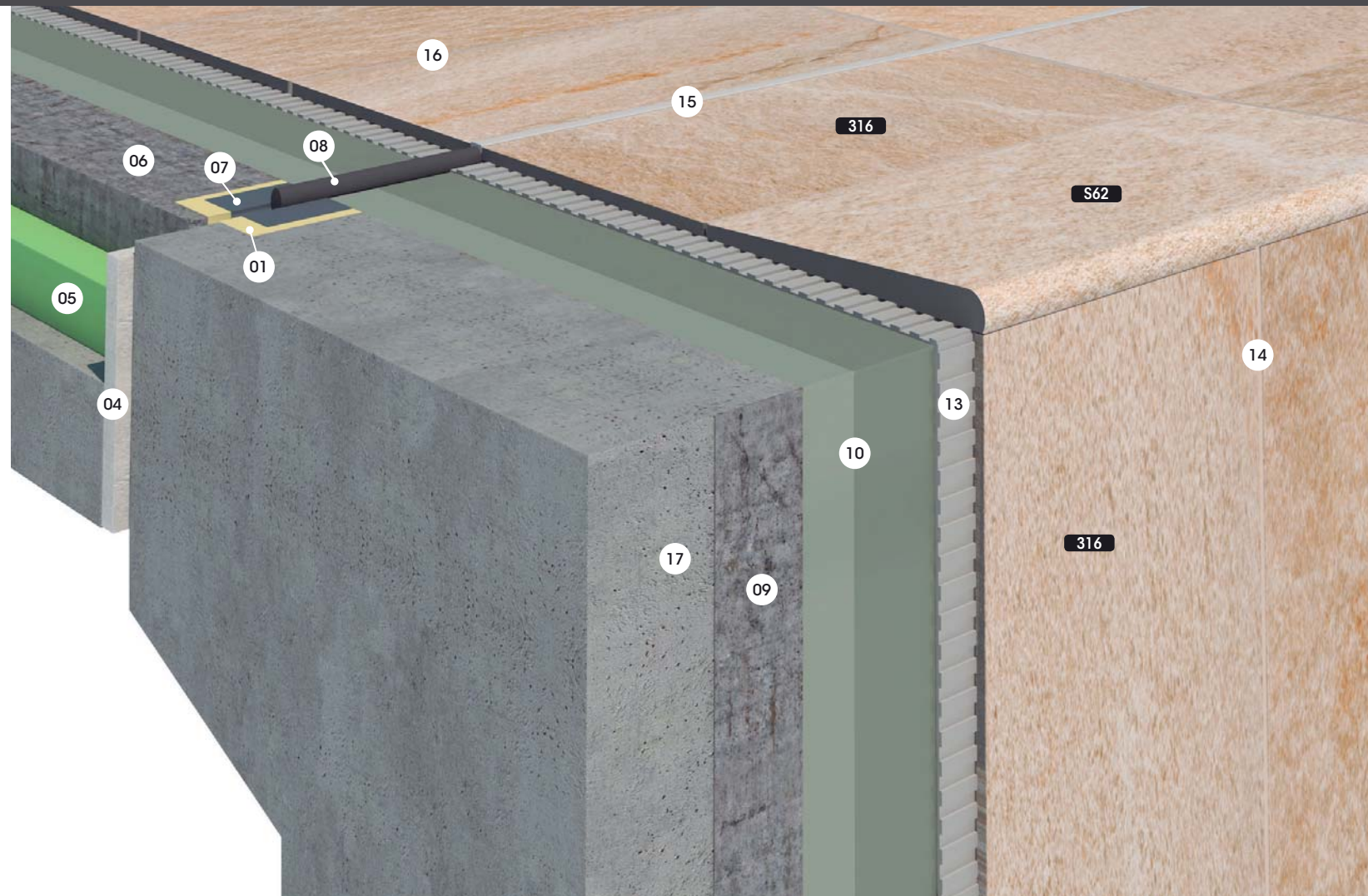

- |                         |                     |                   |                                   |
|-------------------------|---------------------|-------------------|-----------------------------------|
| 01 EPOXICOL             | 07 FIX-TAPE 170 mm  | 13 TECNOCOL FLEX  | 17 Concrete structure of the tank |
| 04 Expanded polystyrene | 08 SELLALASTIC FOAM | 14 CERPOXI        |                                   |
| 05 Extruded polystyrene | 09 FIX-REVOCO       | 15 SELLALASTIC    |                                   |
| 06 PAVIFORT             | 10 HIDROELASTIC     | 16 EUROCOLOR FLEX |                                   |



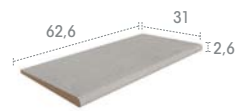
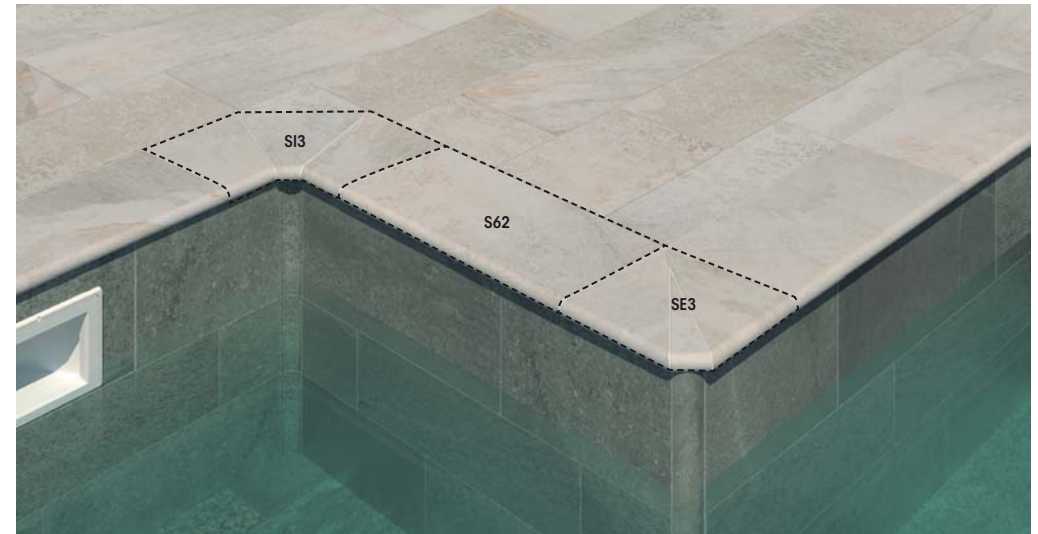

**S62**  
anti-slip

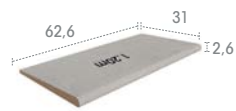

**S62 NU**  
anti-slip



**S13**  
anti-slip

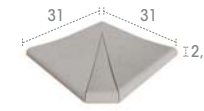

**SE3**  
anti-slip



**Alma**



**Stela**



**Pietro**



**Serena**



**Mistery**

Overflow pools with loungers, steps and vitality area



316



647



664



245 CM



245 EC



L62



183



115



188

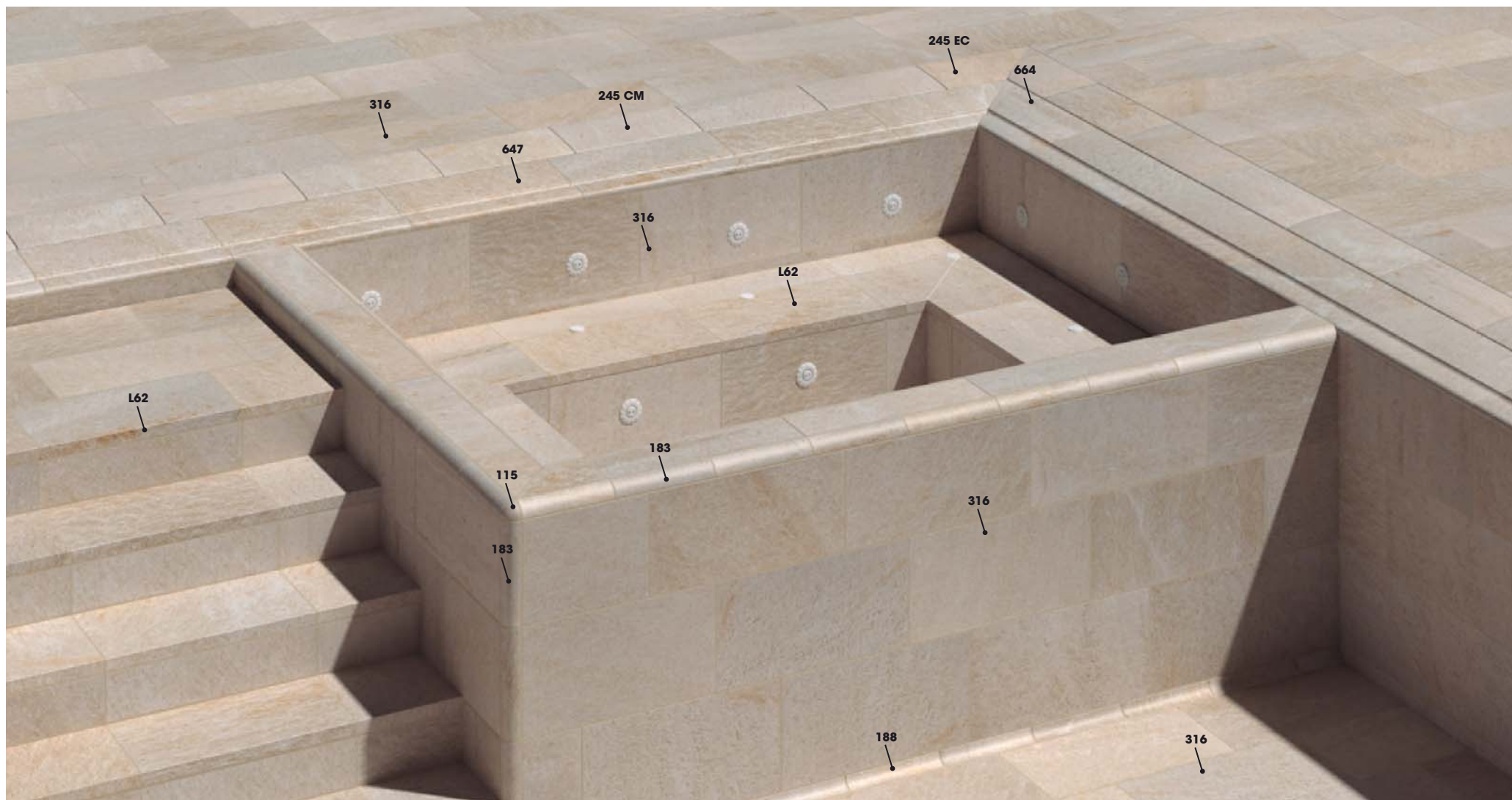

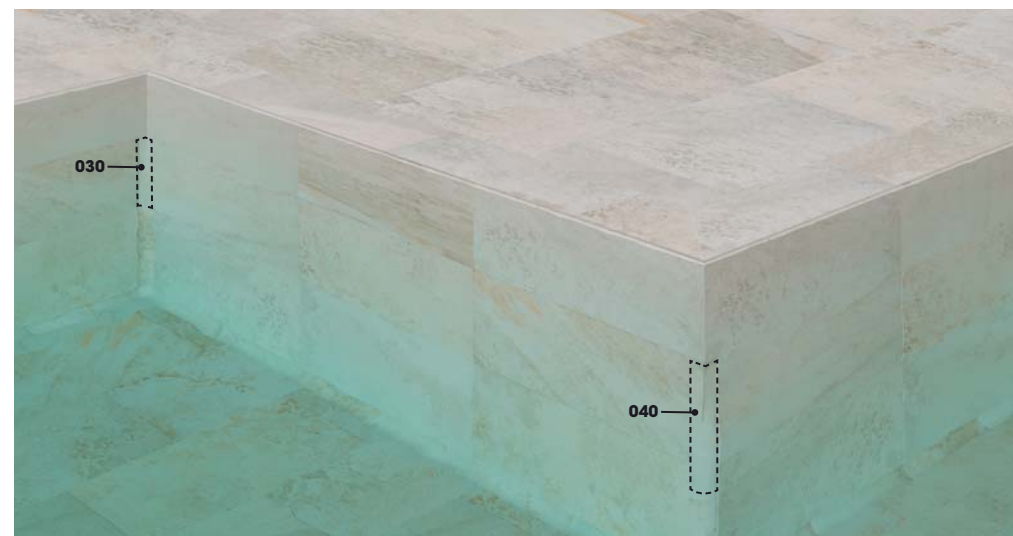
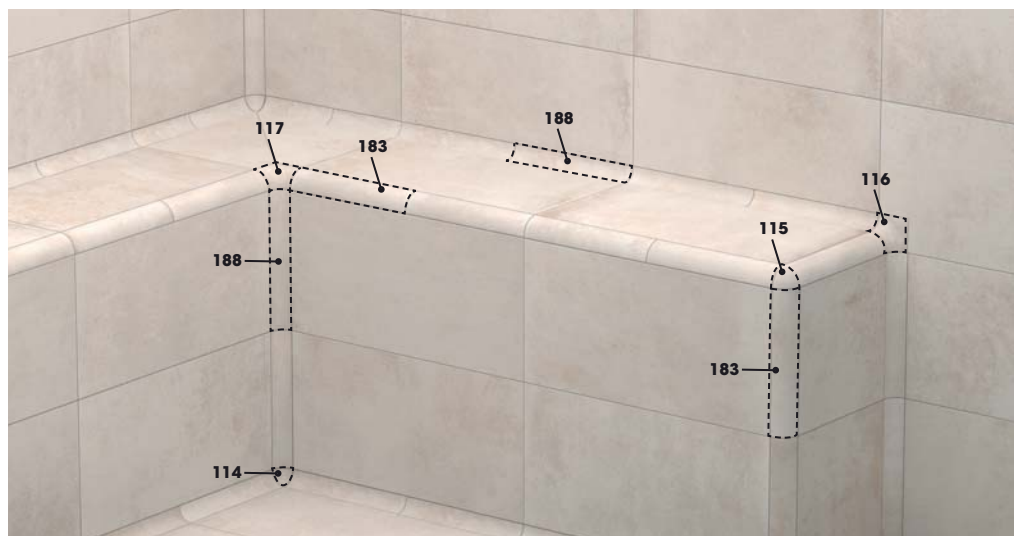

**183**



**115**



**117**

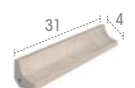

**188**



**114**



**116**



Bullnose

**147**

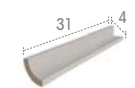

**030**

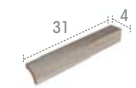

**040**

anti-slip



Trésor



Pietro



Serena

anti-slip / smooth



Mistery

smooth



Mistery

anti-slip



Trésor



Pietro



Serena

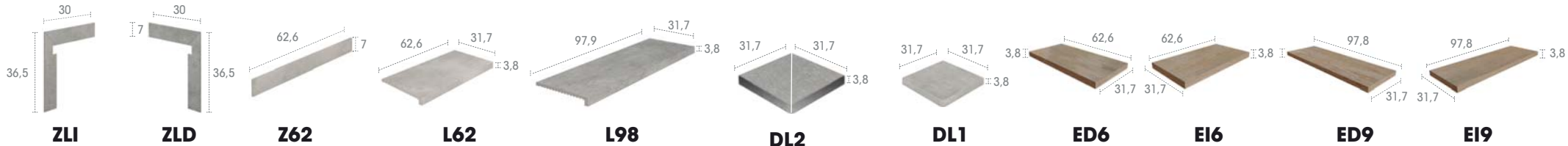
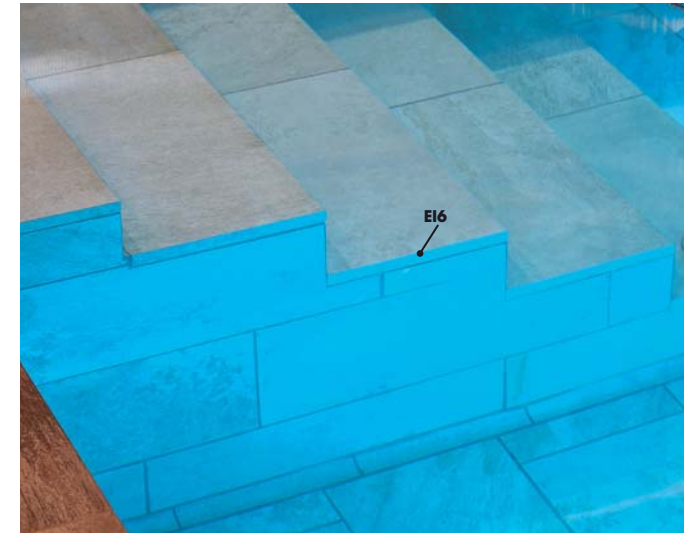
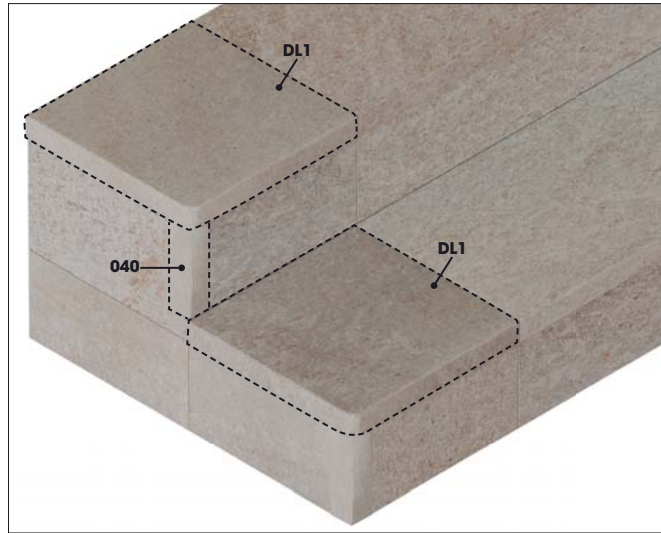
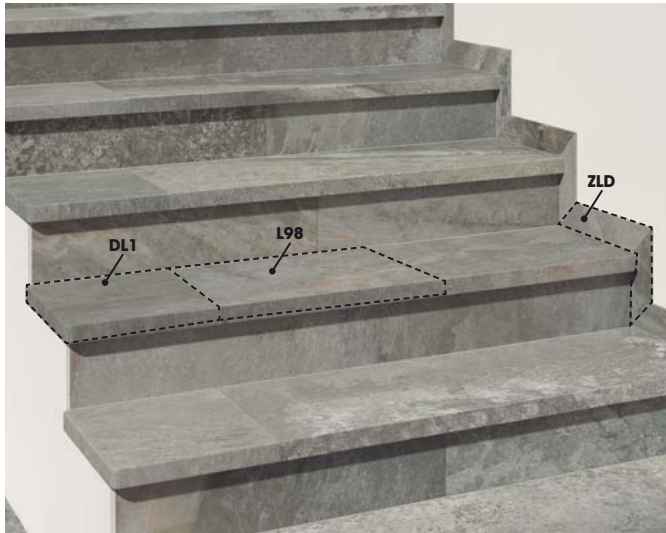

**ZLI      ZLD      Z62      L62      L98      DL2      DL1      ED6      EI6      ED9      EI9**

anti-slip

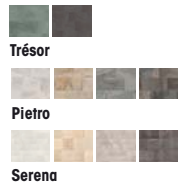

smooth



anti-slip

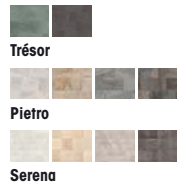

smooth



anti-slip

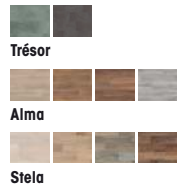

smooth



anti-slip

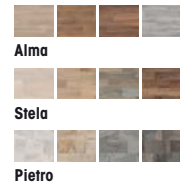

smooth

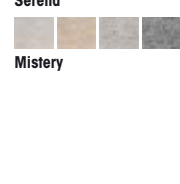

anti-slip

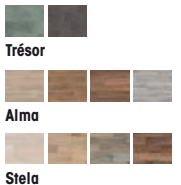

smooth



anti-slip

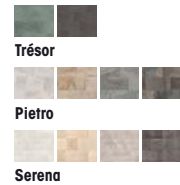

smooth



anti-slip

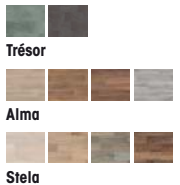

smooth

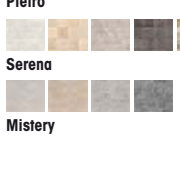

anti-slip

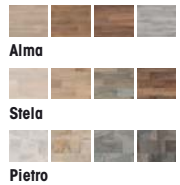

smooth

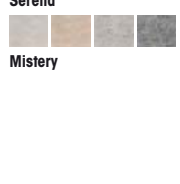

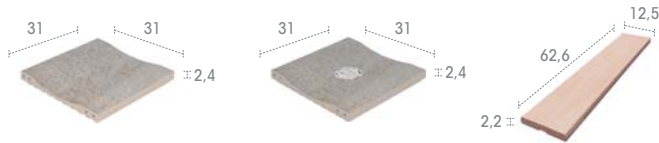
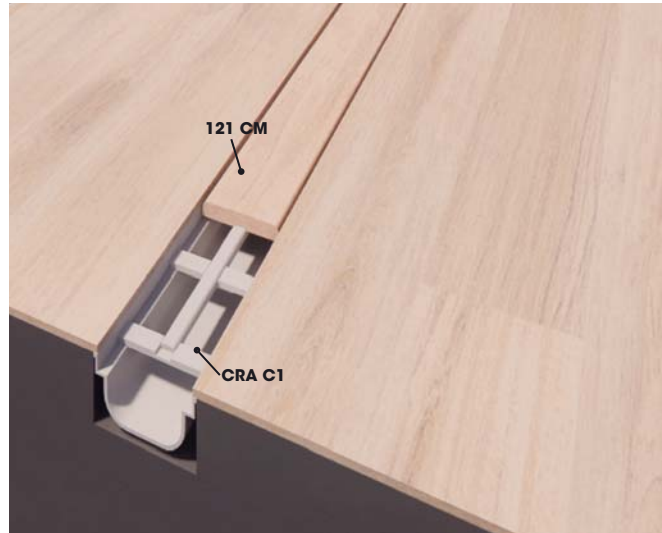

**367**

**368**

**121 CM**

anti-slip



**Trésor**



**Alma**



**Stela**

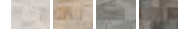

**Pietro**



**Serena**



**Mistery**



**CRA C1**  
PVC  
Channel



**CCR C1**  
PVC  
Junction



**TCR C1**  
PVC  
Terminal Ø 40



**DCR C1**  
PVC  
Drain:  
Side Ø 40  
Base Ø 75





Debrecen Aquaticum Strand | Bord Architect Studio | Photo: Gyorgy Palko  
Aqua, Azul & Marino



# Sport Pools

**COLOURS AND SOLUTIONS  
FOR COMPETITION POOLS**



Debrecen Aquaticum Strand | Bord Architect Studio | Photo: Anna Illés  
Aqua, Azul & Marino



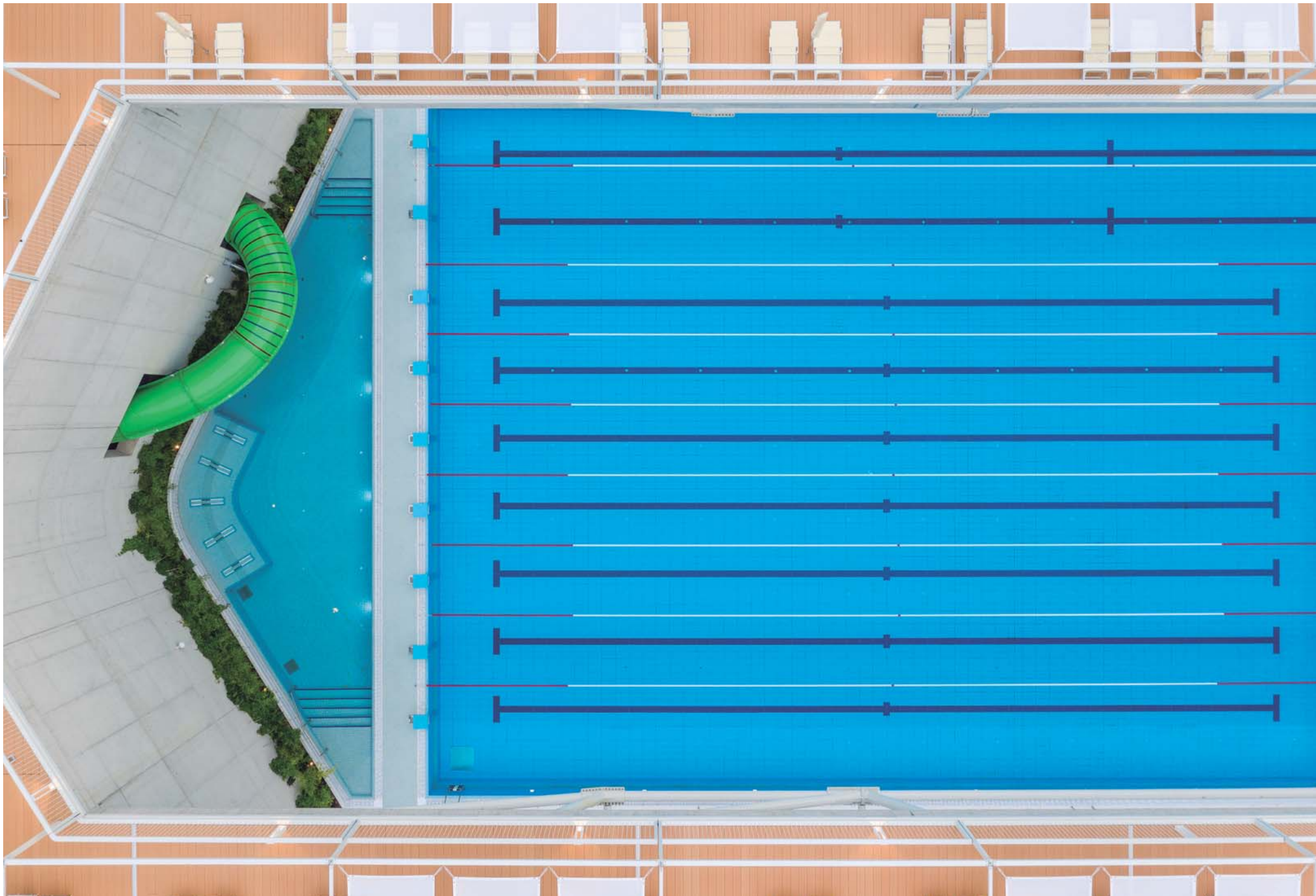

## ANTI-SLIP



244 G1  
smooth / anti-slip  
24,4 x 49,4 x 0,8



122 G1  
smooth / anti-slip  
11,9 x 24,4 x 0,8



052 G1  
smooth  
5,6 x 24,4 x 0,8

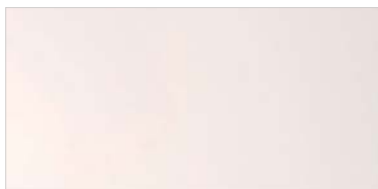

Blanco



Azul



Marino



Plomo



Prusia



Habana



Oliva



Amarillo



Rojo N



## POOL DECKS

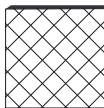

**240 G1  
Pastilla**  
24,4 x 24,4 x 0,8

UNE 41091	DIN 51130	DIN 51097
CLASE 3	R11	CLASE C

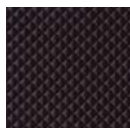

**Plomo Pastilla**  
24,4 x 24,4 x 0,8

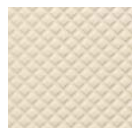

**Indubeige Pastilla**  
24,4 x 24,4 x 0,8



Putxet Sport, Barcelona, Spain  
Indubeige Pastilla

### Waterways

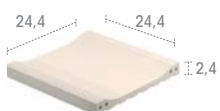

**204**  
anti-slip



**205**  
anti-slip

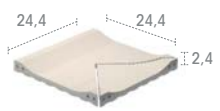

**206**  
anti-slip

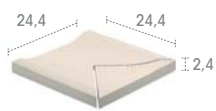

**207**  
anti-slip



Plomo

Indubeige

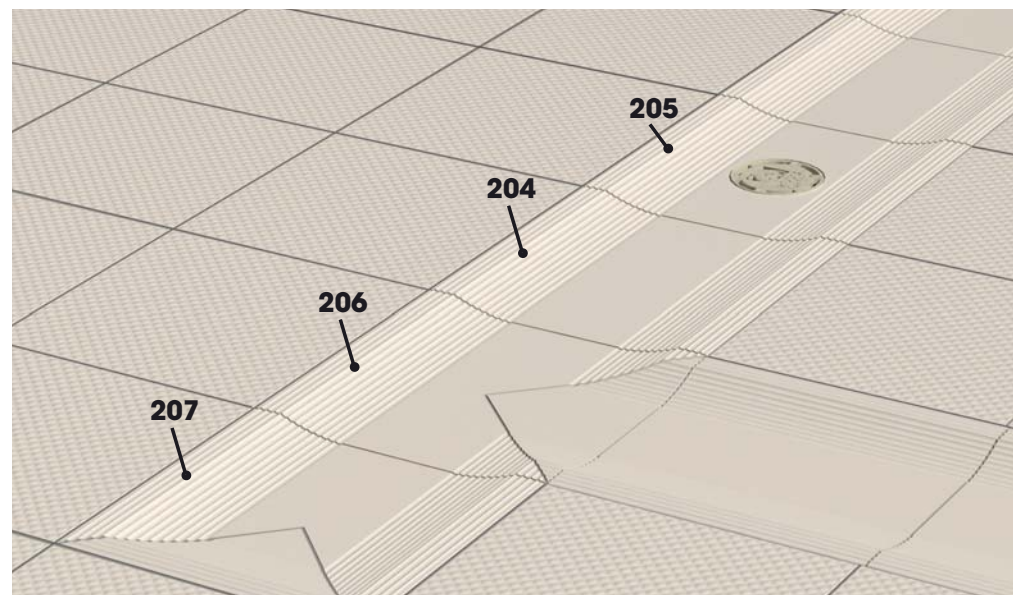

ANTI-SLIP



320  
smooth / anti-slip  
33 x 33 x 0,5  
2,3 x 2,3 / u

323  
smooth / anti-slip  
33 x 33 x 0,5  
2,3 x 4,6 / u

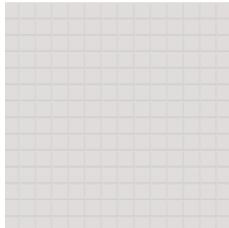

**320**  
**Mosaic Blanco**

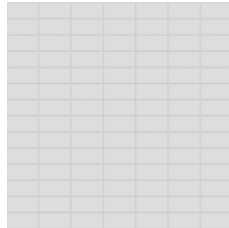

**323**  
**Mosaic Blanco**

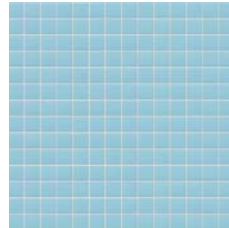

**320**  
**Mosaic Azul**

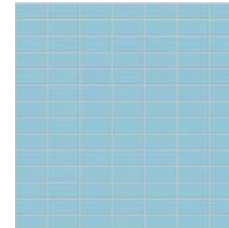

**323**  
**Mosaic Azul**

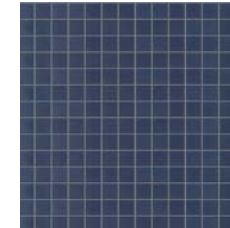

**320**  
**Mosaic Marino**

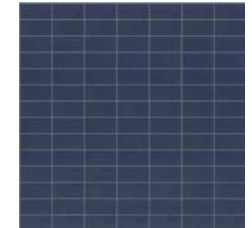

**323**  
**Mosaic Marino**

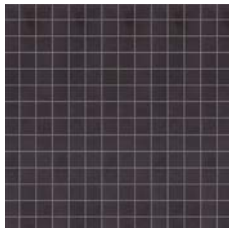

**320**  
**Mosaic Plomo**

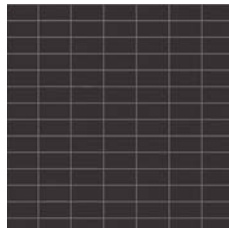

**323**  
**Mosaic Plomo**

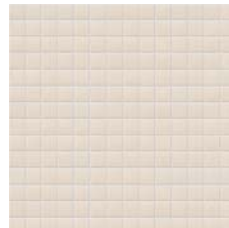

**320**  
**Mosaic Ivory**

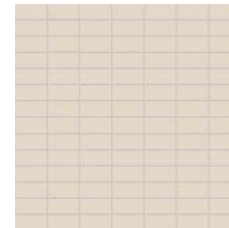

**323**  
**Mosaic Ivory**

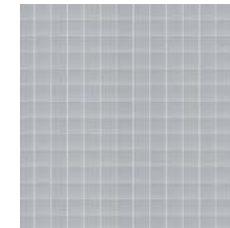

**320**  
**Mosaic Perla**

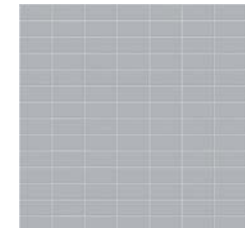

**323**  
**Mosaic Perla**

Glass Mosaic

# Indugres

## 100% **Biostop** Finish

## Ceramic tile that eliminates bacteria

THE ONLY TOTAL SELF-PROTECTION SOLUTION: PORCELAIN CERAMIC TILE AND SEALING GROUT



**BIO-CERPOXI WHITE / 22,5 KG/U**

**BIO-CERPOXI GREY / 21 KG/U**

Coloured epoxy resin resistant to acid and with protective properties: prevents the growth of harmful microorganisms.

**Biostop** (tiles and grout) complies with the **ASTM E 2149, JIS Z 2801** Antimicrobial efficiency regulation and **ISO-22196**.

## Why choose **Biostop**?



### IT WORKS 24/7: INSIDE AND OUTSIDE

**Biostop** does not need light to activate its self-protection properties: it works with artificial light, natural light and even in complete darkness.



### COMPLETE AND PERMANENT PROTECTION

**Biostop's** protection is permanent and 100% safe. It doesn't require any subsequent treatment or maintenance to have an effect.



### PROVED EFFECTIVE AGAINST BACTERIA

**Biostop** completely stops the spread of bacteria such as Staphylococcus aureus, Escherichia coli, Proteus vulgaris, Salmonella Typhi, Enterococcus faecalis, Streptococcus pyogenes, Bacillus and Listeria monocytogenes.



### HIGH-QUALITY INDUSTRIAL PORCELAIN STONEWARE

The manufacturing process behind **Biostop** ensures it retains all the properties usually associated with Rosa Gres industrial porcelain stoneware.



### IT IS NOT HARMFUL TO HEALTH

**Biostop** is non-toxic. It is completely harmless to human health.



### IT REDUCES SMELLS

**Biostop** prevents bad smells that can be caused by micro-organism deposits on the surface.

## Indugres 100% Biostop Finish

### CHANGING ROOMS



**240 G3**  
24,4 x 24,4 x 1



**241 G1**  
24,4 x 49,4 x 0,8



**Indubeige R10**  
24,4 x 24,4 x 1



**Indu Grey R10**  
24,4 x 24,4 x 1



**Indubeige R11**  
24,4 x 24,4 x 1

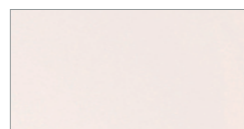

**Bio White Smooth**  
24,4 x 49,4 x 0,8



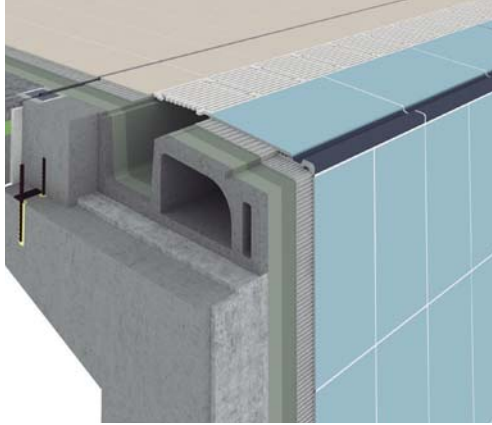

**Horyzon**

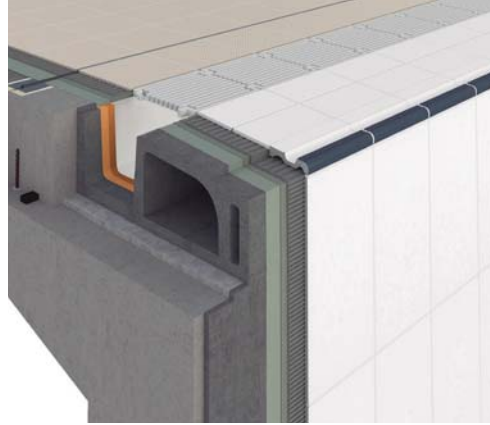

**Finnish**

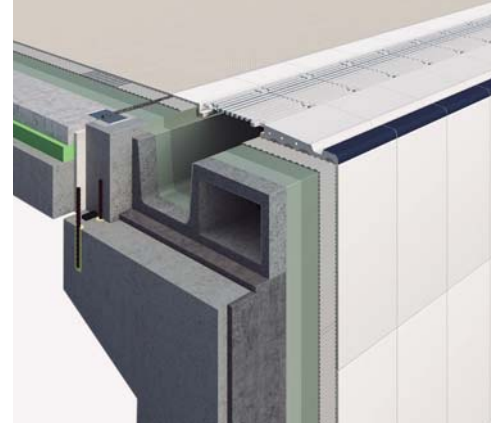

**Ergo**

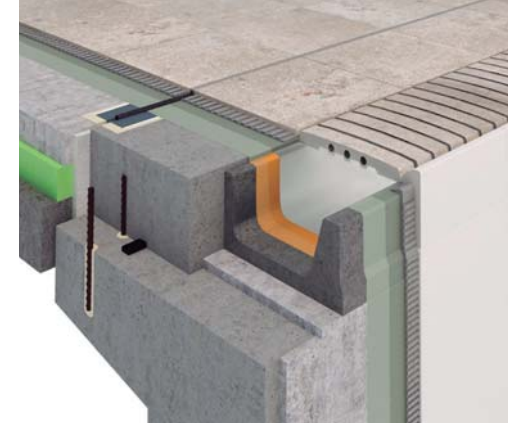

**Wiesbaden**

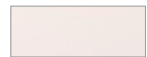

**Blanco**



**Marino Monocolor**



**Azul**



**Plomo Monocolor**

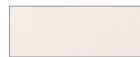

**Blanco**



**Marino Monocolor**



**Azul**



**Plomo Monocolor**



**Indubeige**

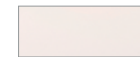

**Blanco**



**Marino Monocolor**



**Azul**



**Plomo Monocolor**



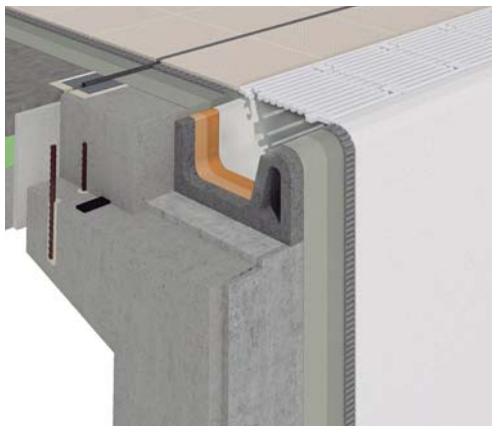

**Spa**



**Zurich**



**Wiesbaden B**

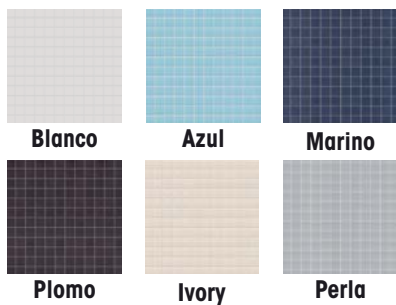

## Horyzon

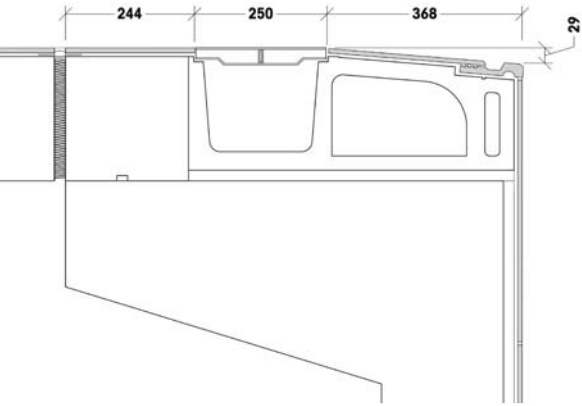

Comprising 2 large format ceramic tiles that form a gentle slope and provide bathers a better grip.

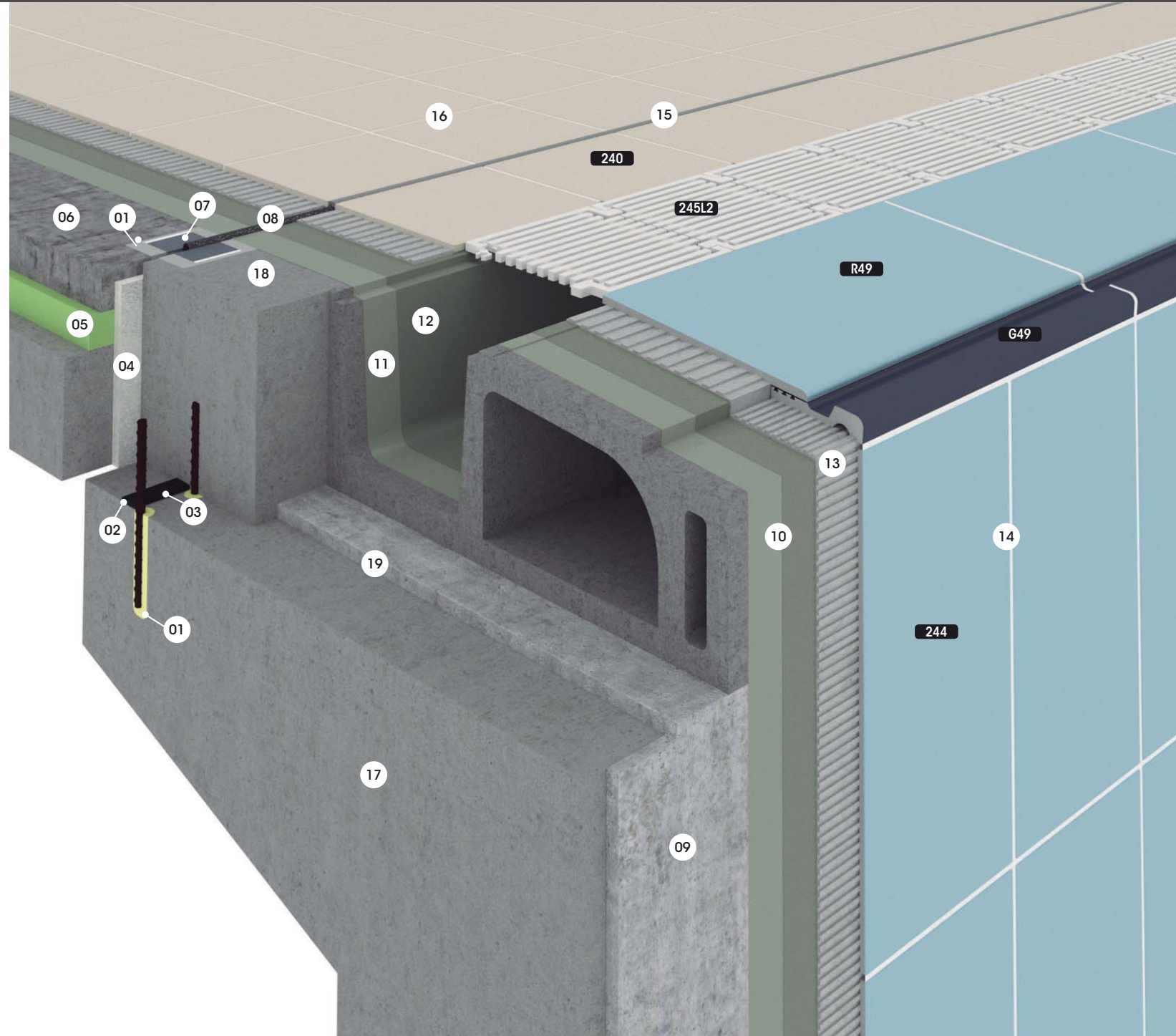

- 01 EPOXICOL
- 02 MASTIC MS
- 03 FUGA-STOP MINI 20 x 10 mm
- 04 Expanded polystyrene
- 05 Extruded polystyrene
- 06 PAVIFORT
- 07 FIX-TAPE 170 mm
- 08 SELLALASTIC FOAM
- 09 FIX-REVOCO
- 10 HIDROELASTIC
- 11 HIDROFIX
- 12 EPOXICOLOR
- 13 TECNOCOL FLEX
- 14 CERPOXI
- 15 SELLALASTIC
- 16 EUROCOLOR FLEX
- 17 Concrete structure of the tank
- 18 Wall behind the Rosa Gres S9 blocks
- 19 Improved adhesive mortar with Primfix to fix S9 pieces



Public Pool, Alos de Balaguer, Spain  
Azul & Marino

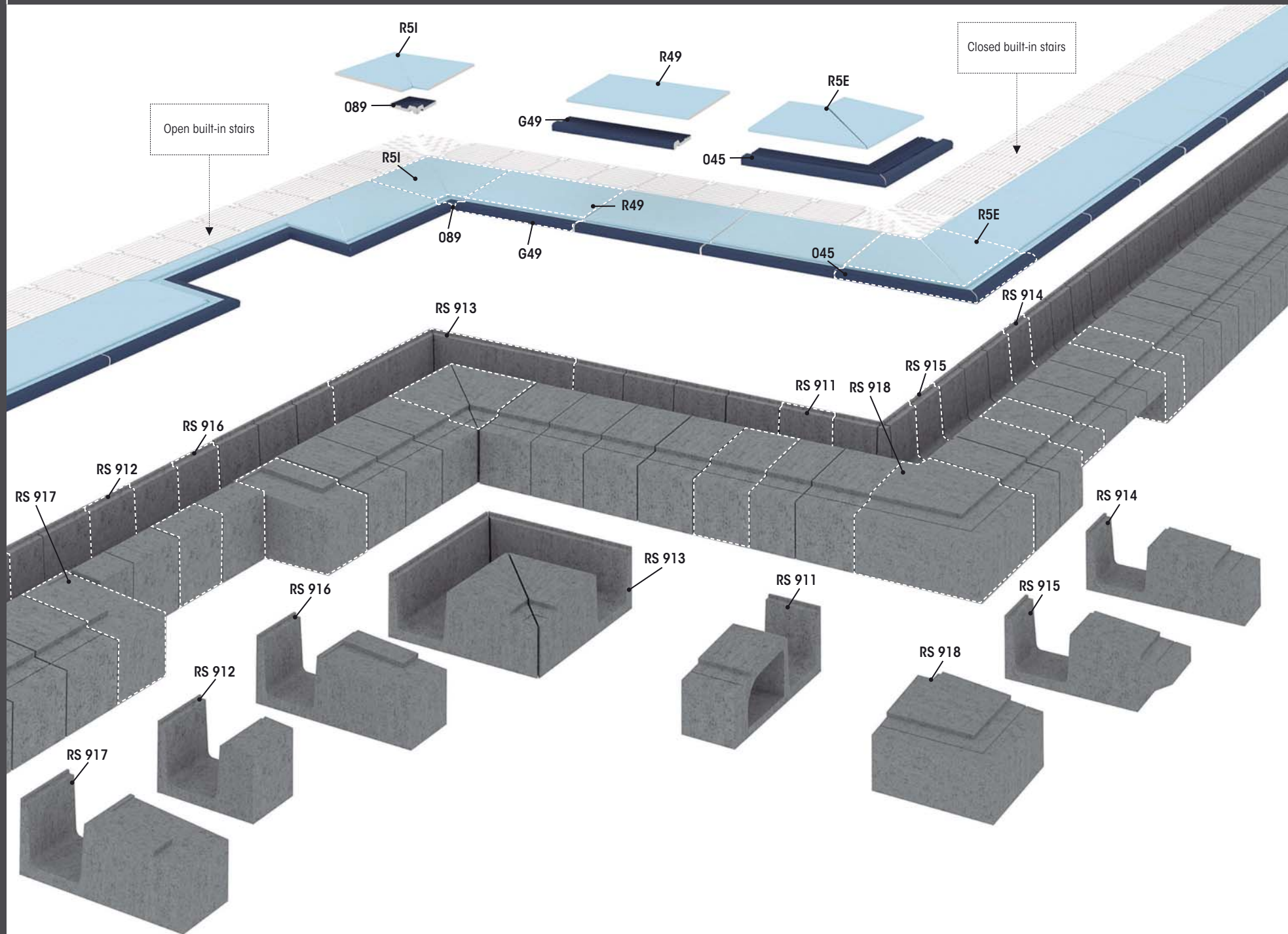

Coping tiles and corners

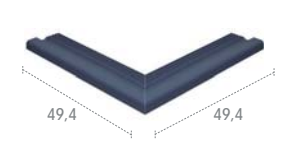
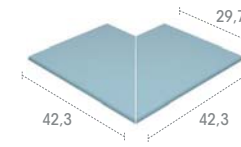
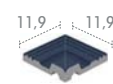
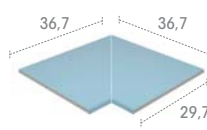
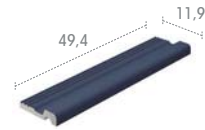
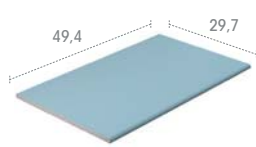
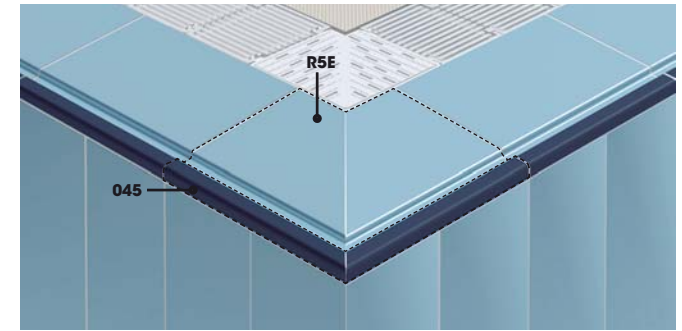
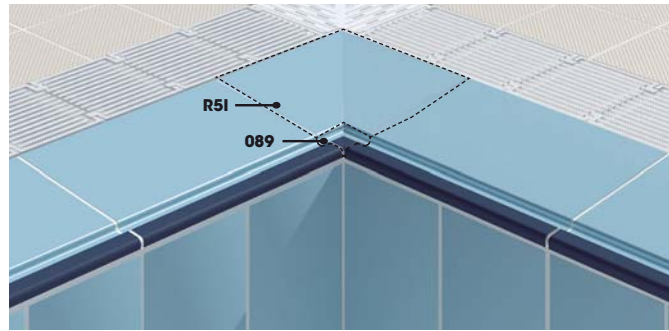
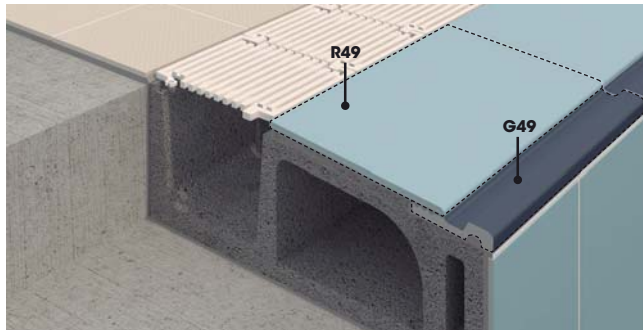

**R49**  
anti-slip

**G49**  
anti-slip

**R51**  
anti-slip

**089**  
anti-slip

**R5E**  
anti-slip

**045**  
anti-slip



S9 Blocks

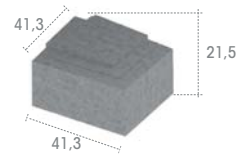
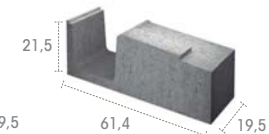
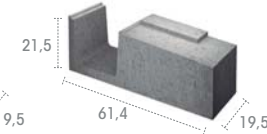
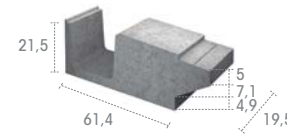
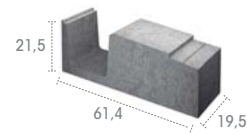
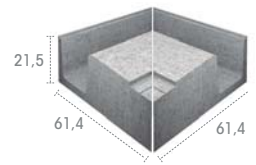
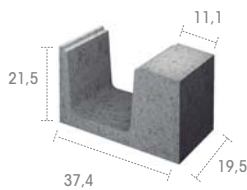
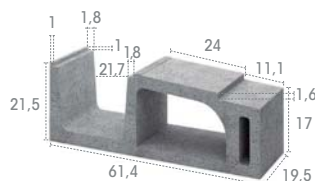

**RS 911**

Base

**RS 912**

Open built-in stairs

**RS 913**

Inside corner

**RS 914**

Solid

**RS 915**

Closed built-in stairs

**RS 916**

Open built-in stairs,  
right corner

**RS 917**

Open built-in stairs,  
left corner

**RS 918**

Outside corner

## Finnish

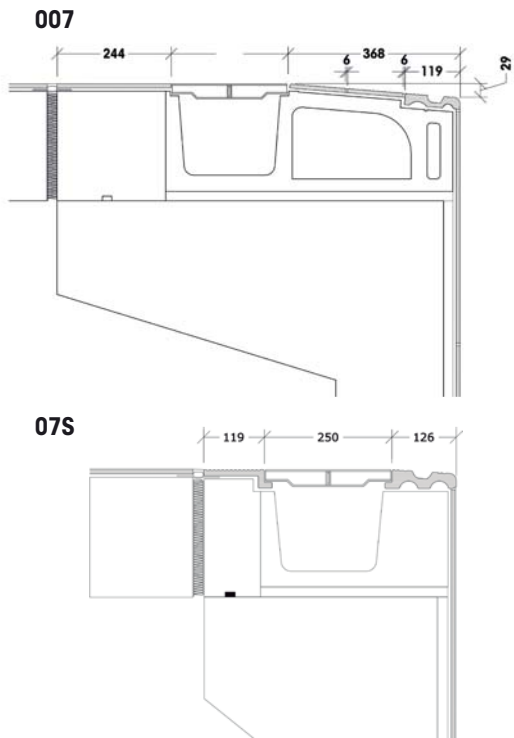

A classic downward-sloping pre-deck system. The S9 blocks provide the necessary slope and grate support.

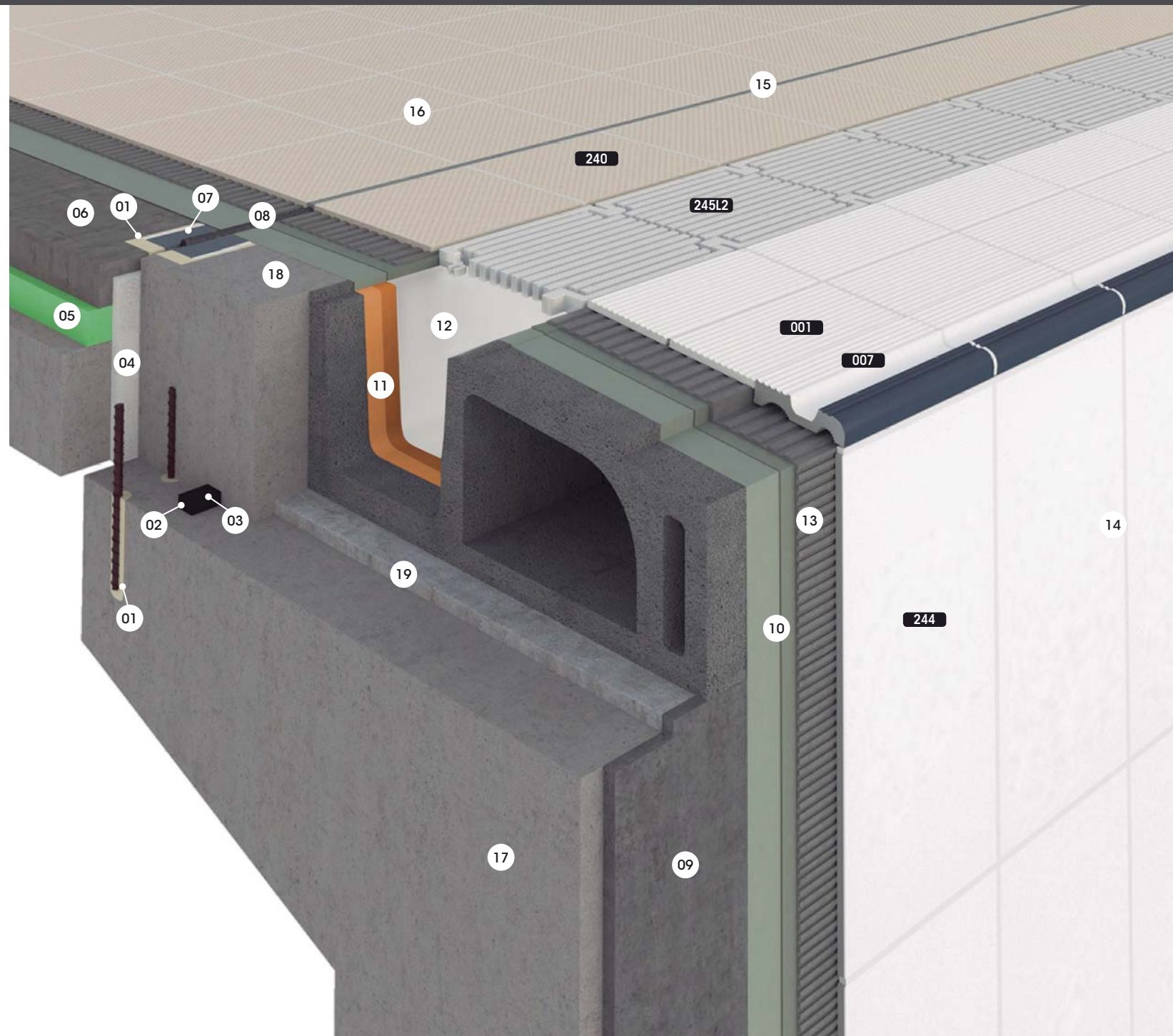

- 01 EPOXICOL
- 02 MASTIC MS
- 03 FUGA-STOP MINI 20 x 10 mm
- 04 Expanded polystyrene
- 05 Extruded polystyrene
- 06 PAVIFORT
- 07 FIX-TAPE 170 mm
- 08 SELLALASTIC FOAM
- 09 FIX-REVOCO
- 10 HIDROELASTIC
- 11 HIDROFIX
- 12 EPOXICOLOR
- 13 TECNOCOL FLEX
- 14 CERPOXI
- 15 SELLALASTIC
- 16 EUROCOLOR FLEX
- 17 Concrete structure of the tank
- 18 Wall behind the Rosa Gres S9 blocks
- 19 Improved adhesive mortar with Primfix to fix S9 pieces



Deportivo Venustiano Carranza, Ciudad de México, México  
Plomo | Blanco | Mistery Grey

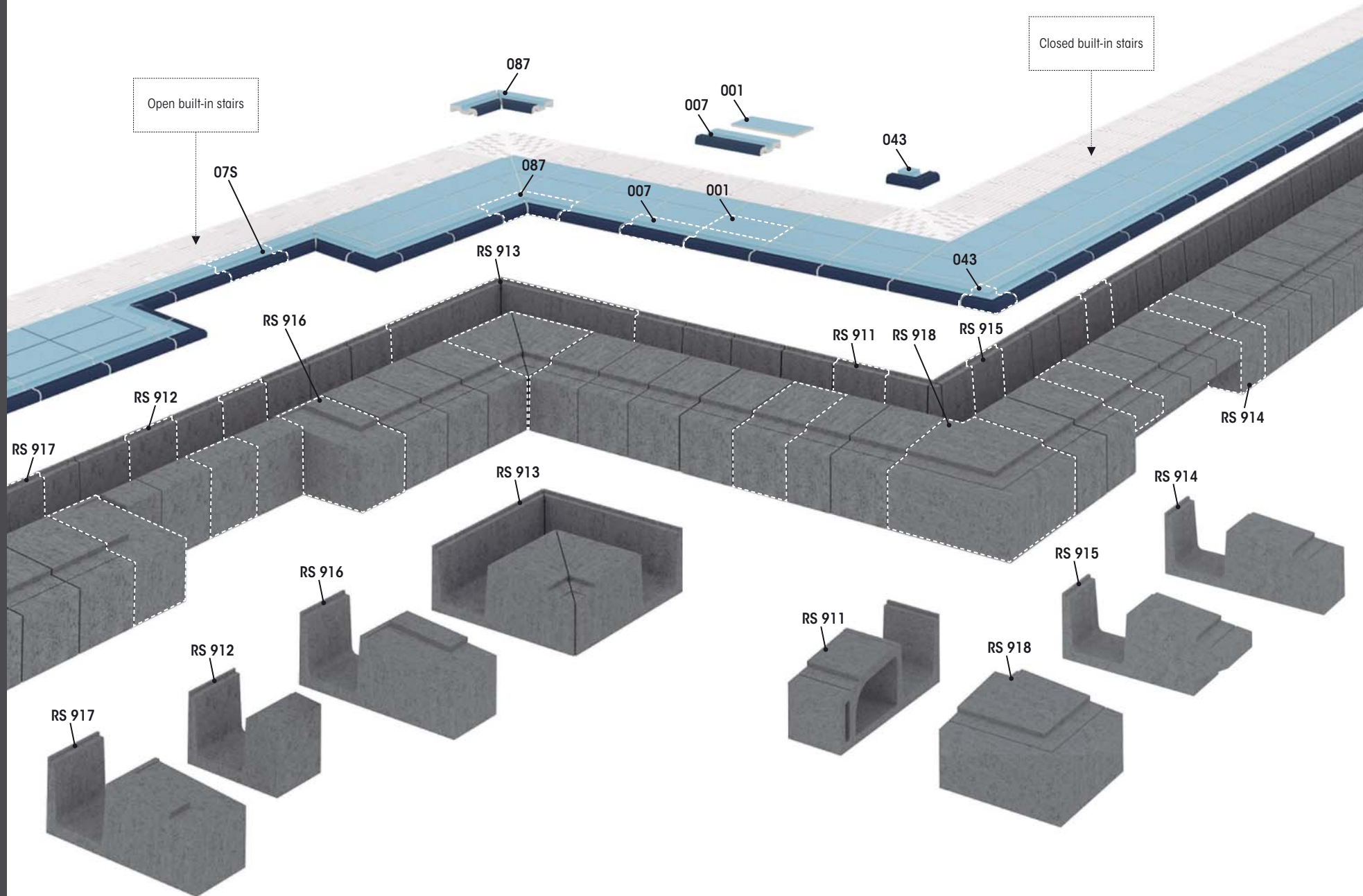



Coping files and corners

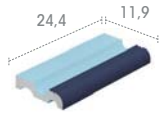

**007**  
anti-slip

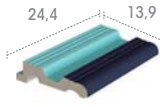

**07S**  
anti-slip

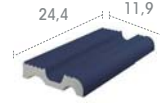

**007M**  
anti-slip

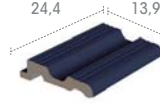

**07SM**  
anti-slip

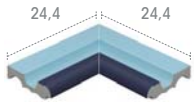

**087**  
anti-slip

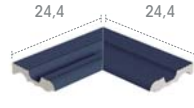

**087M**  
anti-slip

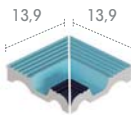

**88S**  
anti-slip

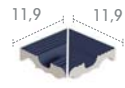

**088M**  
anti-slip

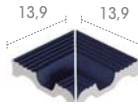

**88SM**  
anti-slip

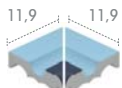

**088**  
anti-slip

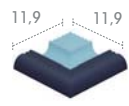

**043**  
anti-slip

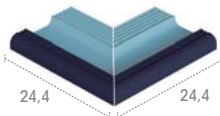

**43S**  
anti-slip

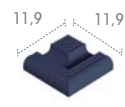

**043M**  
anti-slip

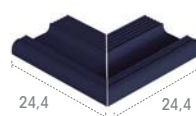

**43SM**  
anti-slip

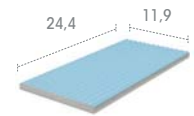

**001**  
anti-slip

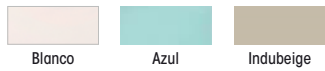

S9 Blocks

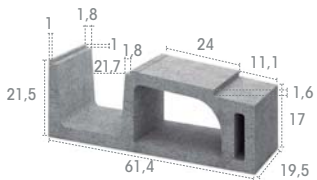

**RS 911**

Base

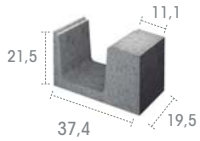

**RS 912**

Open built-in stairs

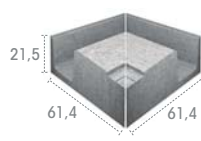

**RS 913**

Inside corner

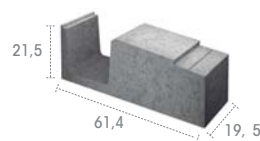

**RS 914**

Solid

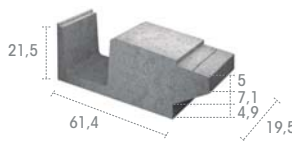

**RS 915**

Closed built-in stairs

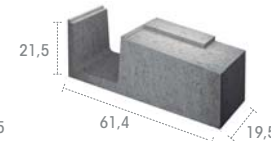

**RS 916**

Open built-in stairs,  
right corner

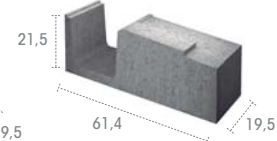

**RS 917**

Open built-in stairs,  
left corner

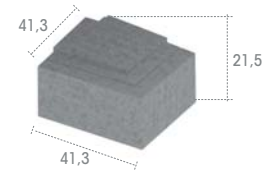

**RS 918**

Outside corner

## Ergo

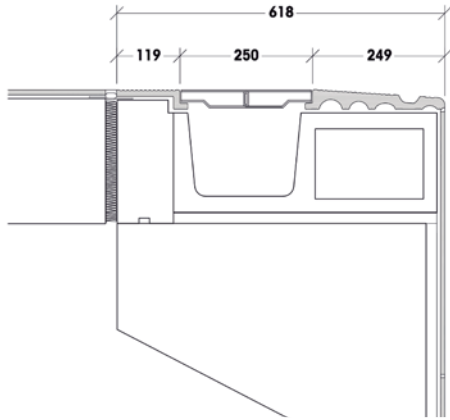

A downward-sloping pre-deck system with only two pieces. The edge piece provides the pre-deck slope and acts as a ceramic support for the grate.

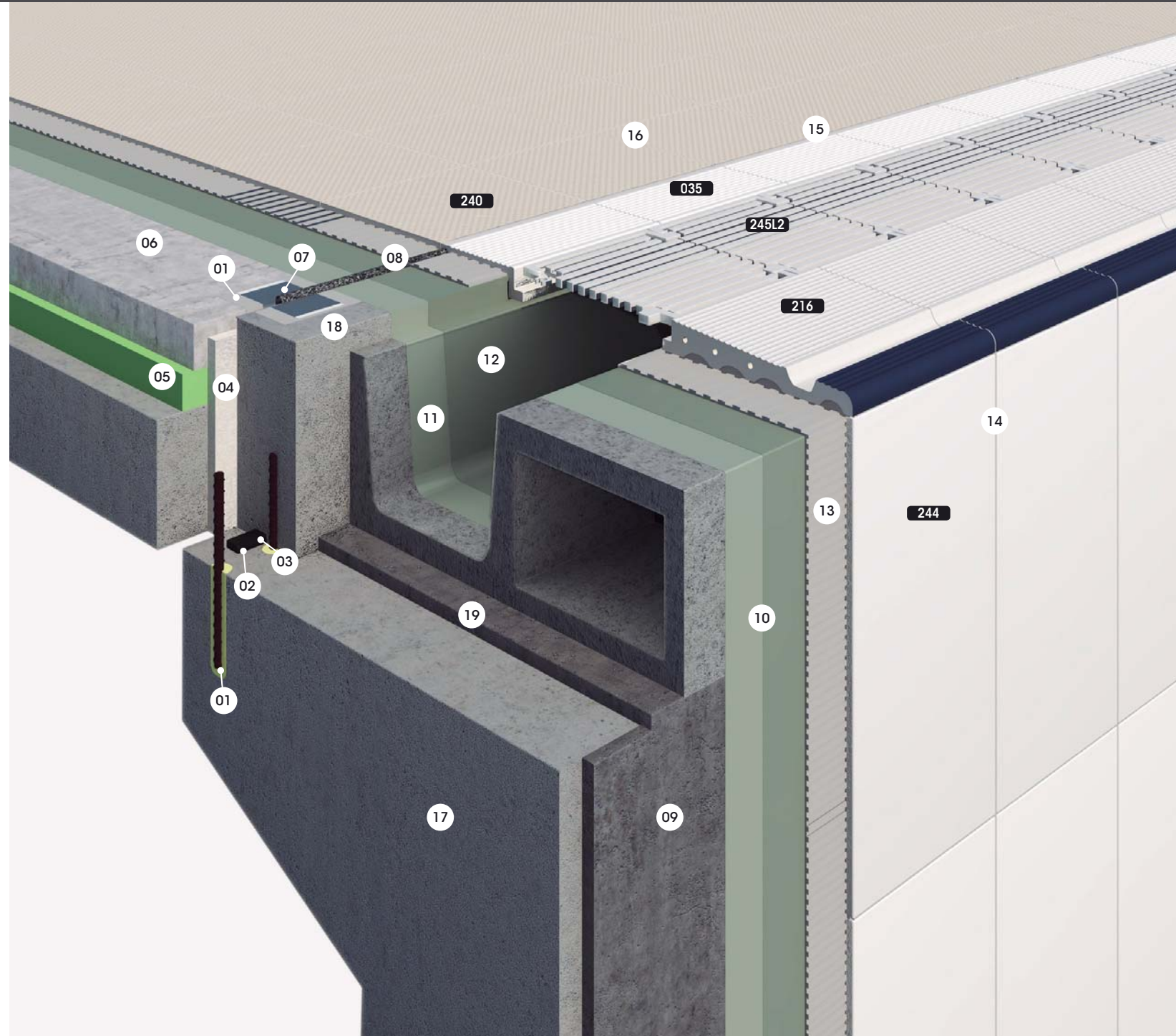

- 01 EPOXICOL
- 02 MASTIC MS
- 03 FUGA-STOP MINI 20 x 10 mm
- 04 Expanded polystyrene
- 05 Extruded polystyrene
- 06 PAVIFORT
- 07 FIX-TAPE 170 mm
- 08 SELLALASTIC FOAM
- 09 FIX-REVOCO
- 10 HIDROELASTIC
- 11 HIDROFIX
- 12 EPOXICOLOR
- 13 TECNOCOL FLEX
- 14 CERPOXI
- 15 SELLALASTIC
- 16 EUROCOLOR FLEX
- 17 Concrete structure of the tank
- 18 Wall behind the Rosa Gres S9 blocks
- 19 Improved adhesive mortar with Primfix to fix S9 pieces



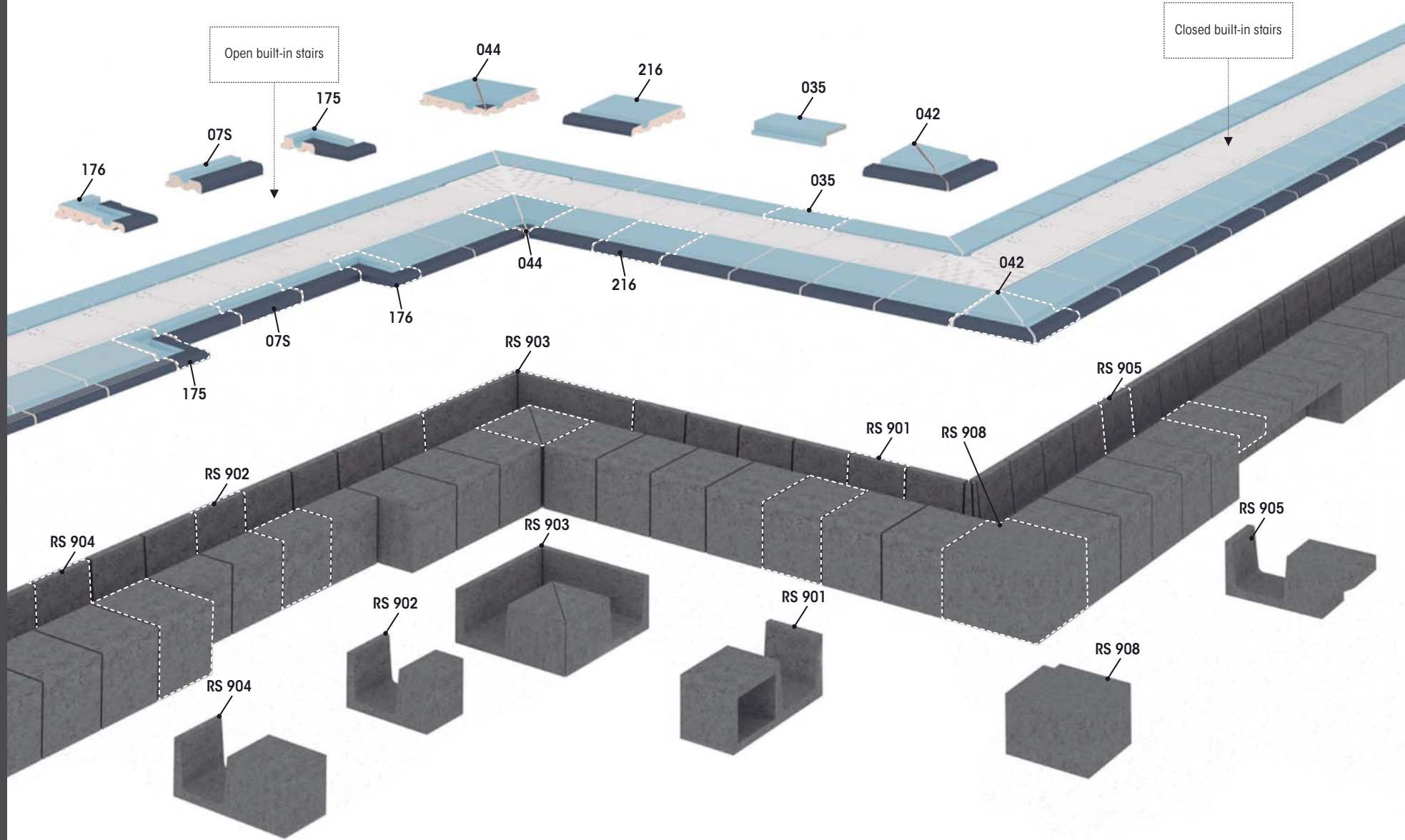

Coping tiles and corners

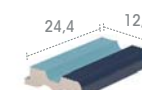
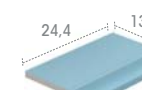
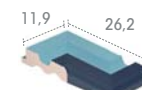
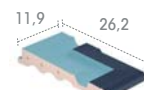
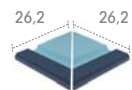
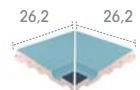
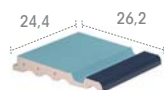
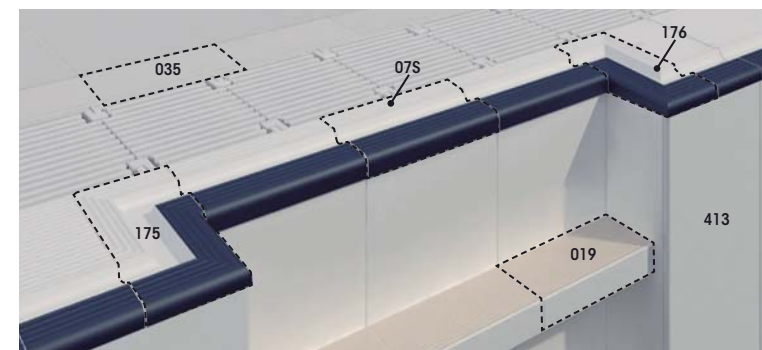
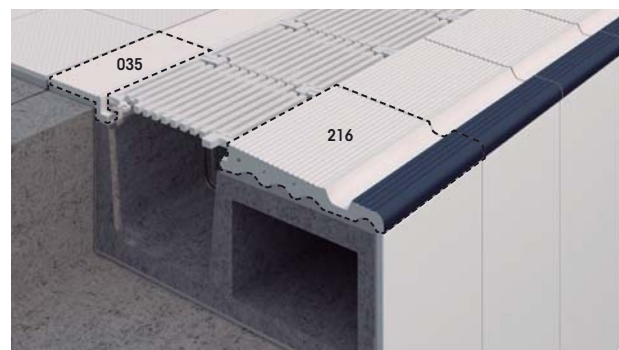
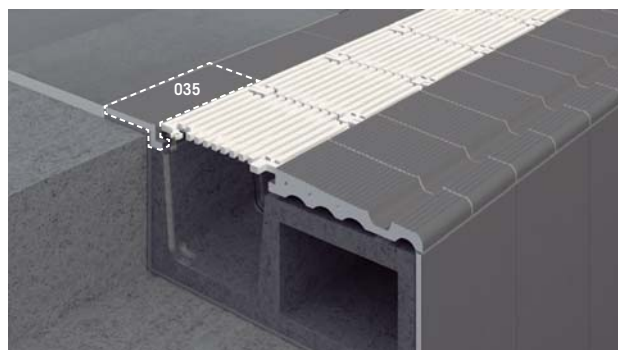

**216**  
anti-slip

**044**  
anti-slip

**042**  
anti-slip

**175**  
anti-slip

**176**  
anti-slip

**035**  
anti-slip

**07S**  
anti-slip



S9 Blocks

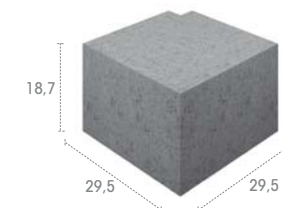
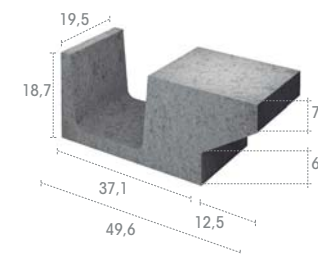
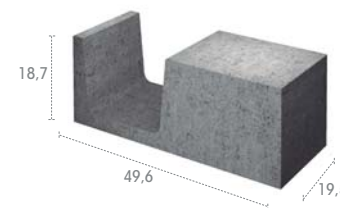
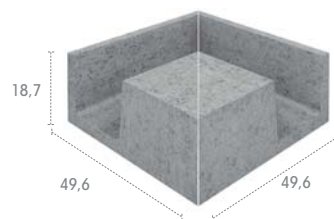
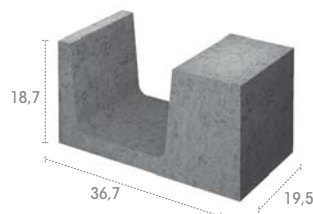
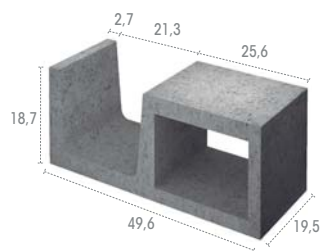

**RS 901**  
Base

**RS 902**  
Open built-in stairs

**RS 903**  
Inside corner

**RS 904**  
Solid

**RS 905**  
Closed built-in stairs

**RS 908**  
Outside corner

## Wiesbaden

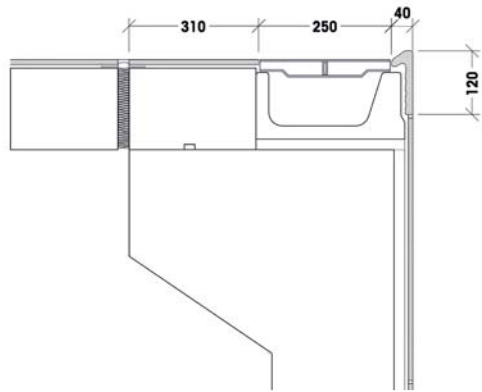

This is ideal if you have a limited pool deck area and require a low price, guaranteed watertightness, a high-capacity channel, an easy installation and a wide range of colors.

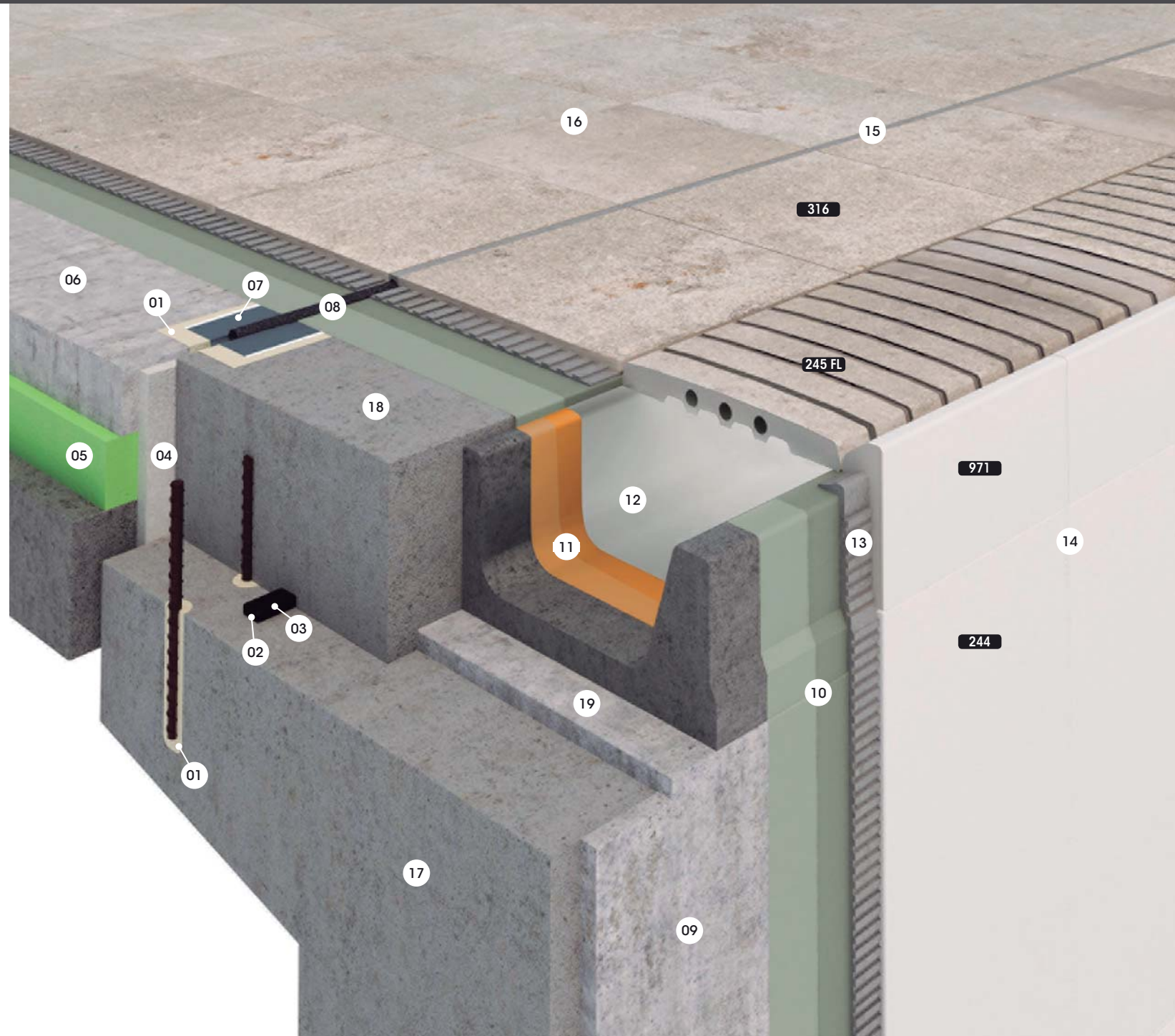

- 01 EPOXICOL
- 02 MASTIC MS
- 03 FUGA-STOP MINI 20 x 10 mm
- 04 Expanded polystyrene
- 05 Extruded polystyrene
- 06 PAVIFORT
- 07 FIX-TAPE 170 mm
- 08 SELLALASTIC FOAM
- 09 FIX-REVOCO
- 10 HIDROELASTIC
- 11 HIDROFIX
- 12 EPOXICOLOR
- 13 TECNOCOL FLEX
- 14 CERPOXI
- 15 SELLALASTIC
- 16 EUROCOLOR FLEX
- 17 Concrete structure of the tank
- 18 Wall behind the Rosa Gres S9 blocks
- 19 Improved adhesive mortar with Primfix to fix S9 pieces



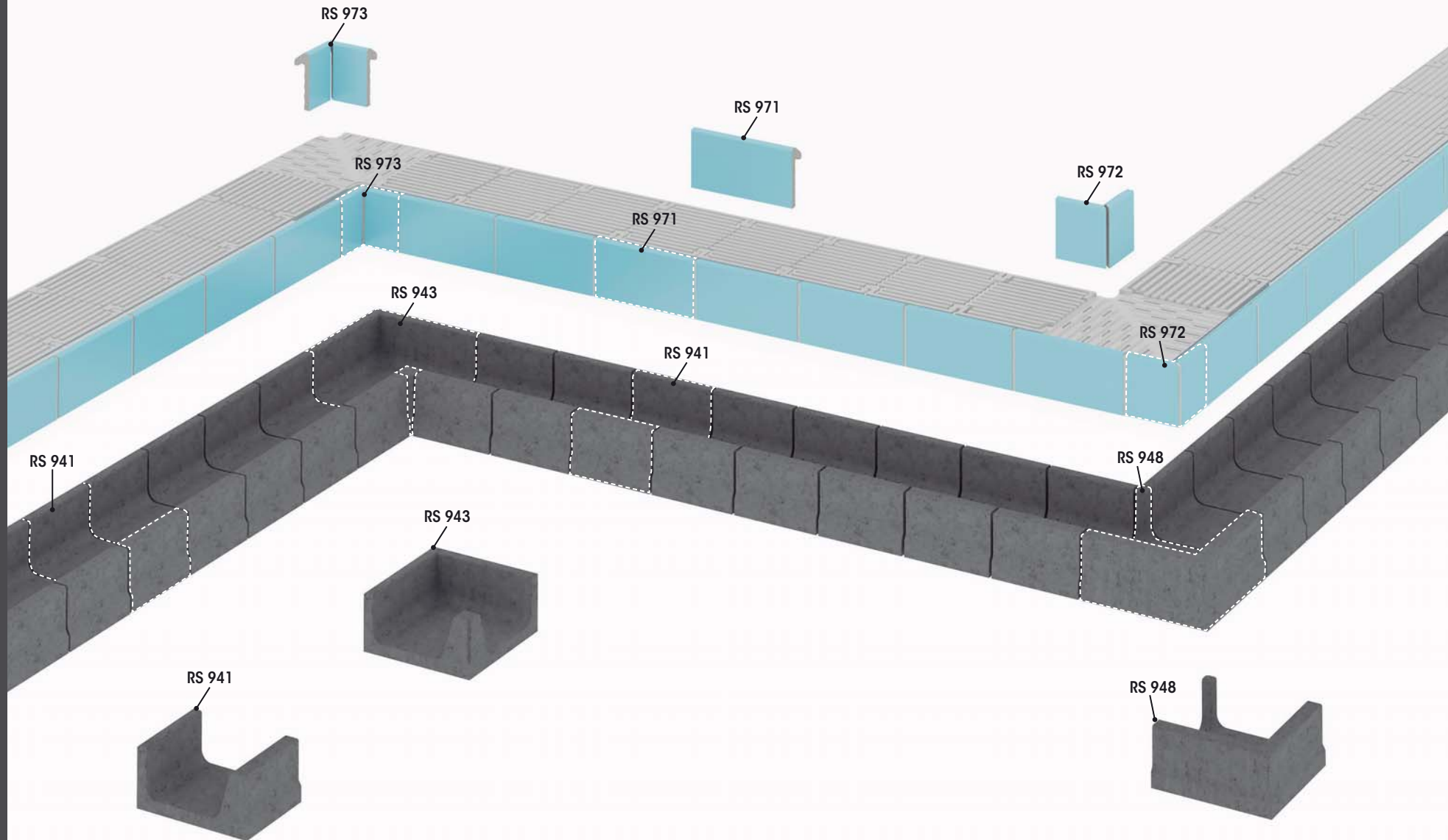



Coping tiles and corners

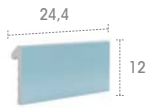
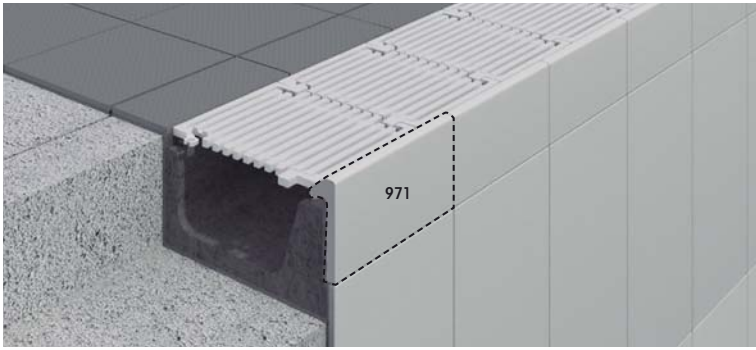

**971**  
anti-slip

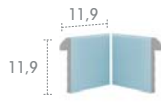

**973**  
anti-slip

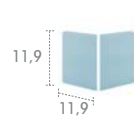

**972**  
anti-slip



S9 Blocks

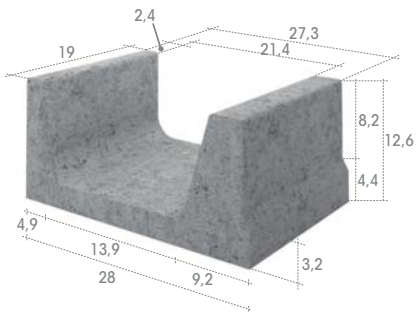

**RS 941**

Base

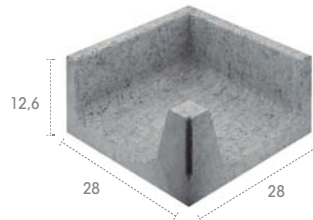

**RS 943**

Inside corner

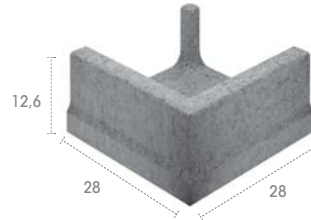

**RS 948**

Outside corner



Aquaworld, Concorezzo, Italy | Federico Pella, Sering SRL, Architects  
Aqua

## Spa

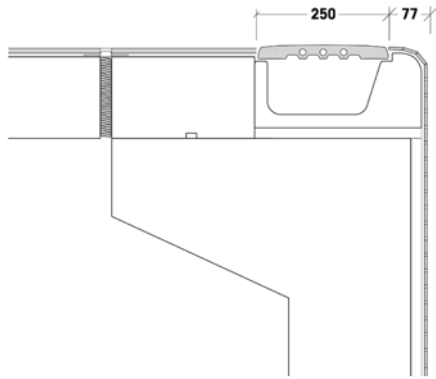

Created to simplify the construction of deck level pools with mosaic, both public and private. Its main advantages are ease of construction, low cost, speed, reduced space and the vast range of colour combinations.

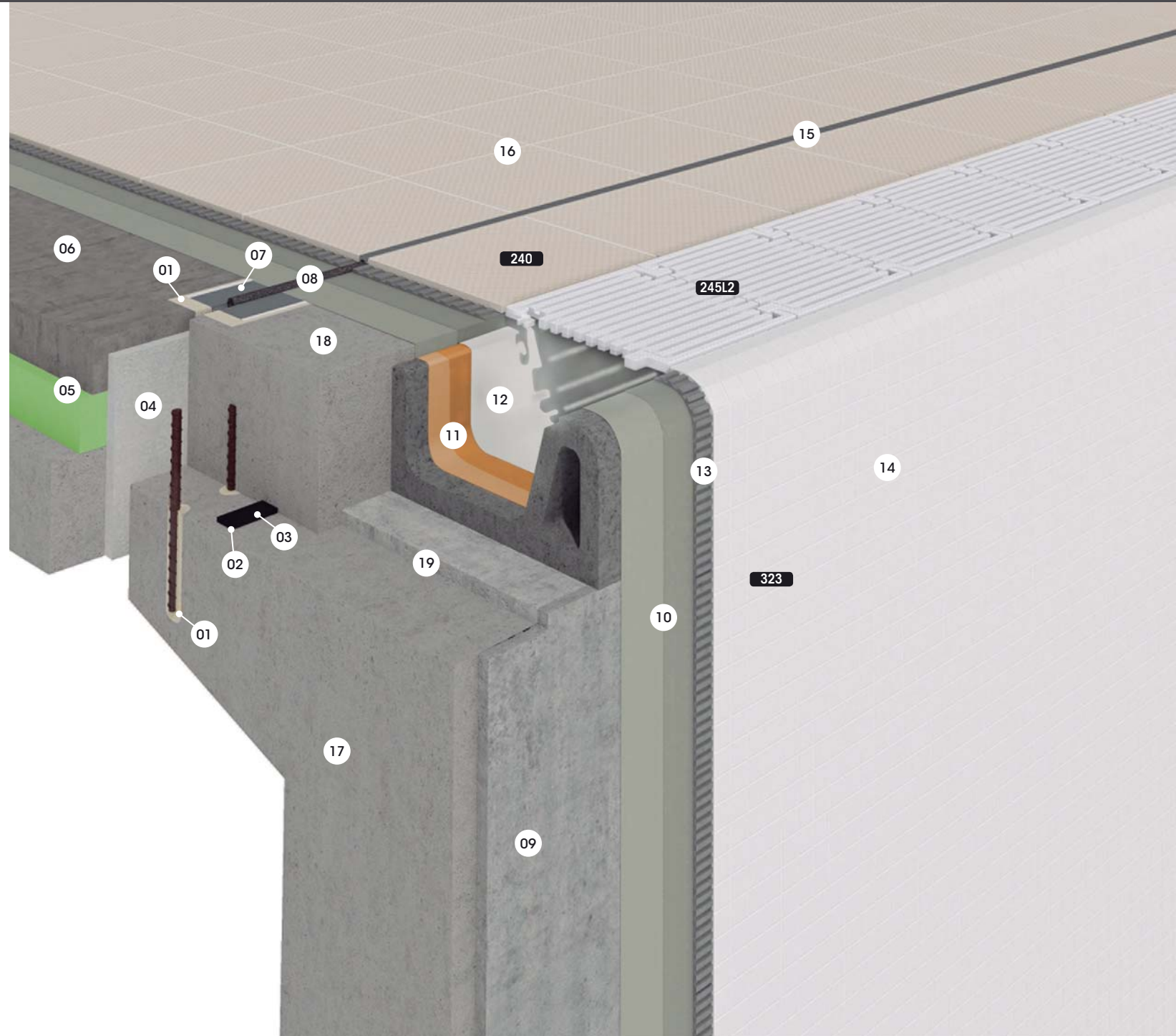

- 01 EPOXICOL
- 02 MASTIC MS
- 03 FUGA-STOP MINI 20 x 10 mm
- 04 Expanded polystyrene
- 05 Extruded polystyrene
- 06 PAVIFORT
- 07 FIX-TAPE 170 mm
- 08 SELLALASTIC FOAM
- 09 FIX-REVOCO
- 10 HIDROELASTIC
- 11 HIDROFIX
- 12 EPOXICOLOR
- 13 TECNOCOL FLEX
- 14 CERPOXI
- 15 SELLALASTIC
- 16 EUROCOLOR FLEX
- 17 Concrete structure of the tank
- 18 Wall behind the Rosa Gres S9 blocks
- 19 Improved adhesive mortar with Primfix to fix S9 pieces



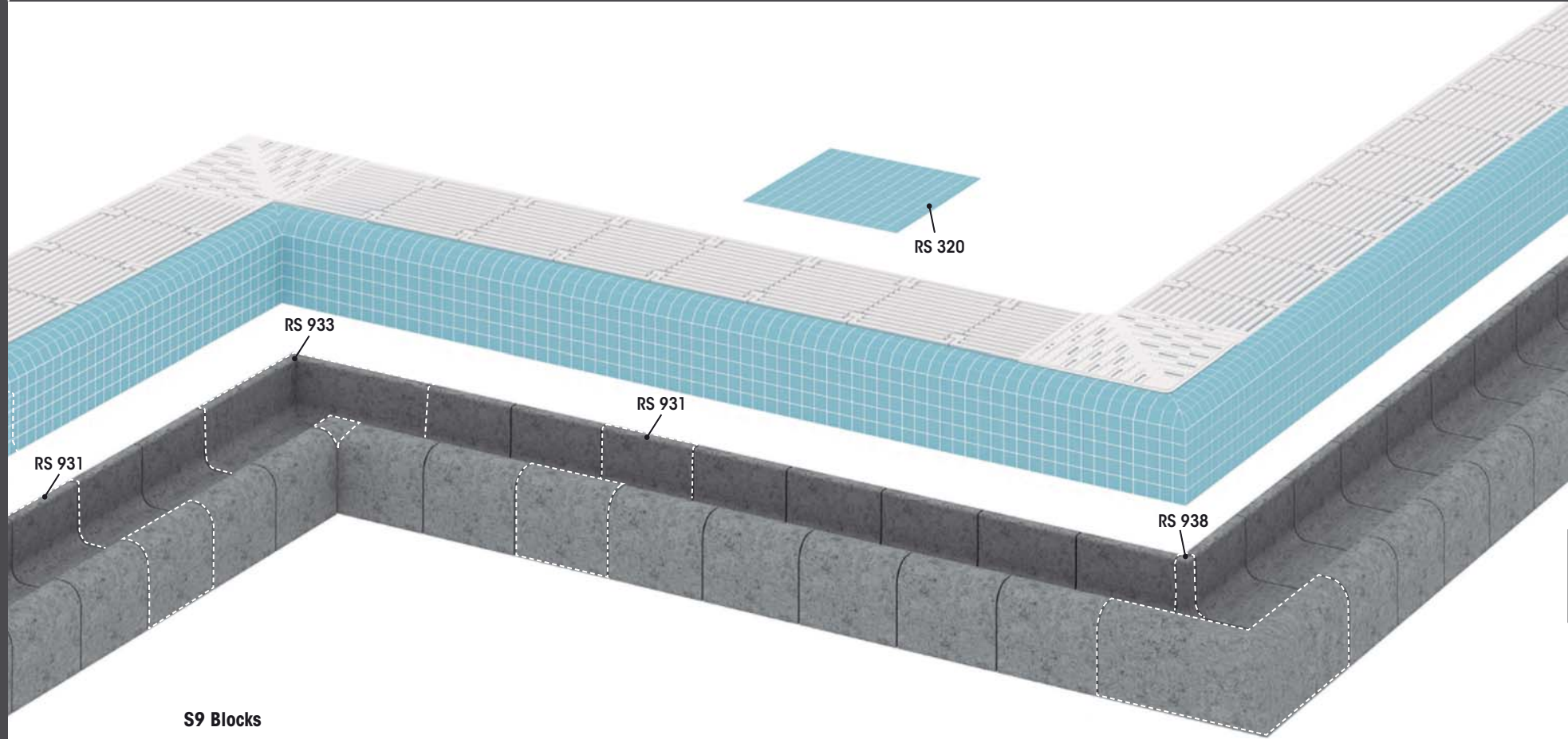

**S9 Blocks**

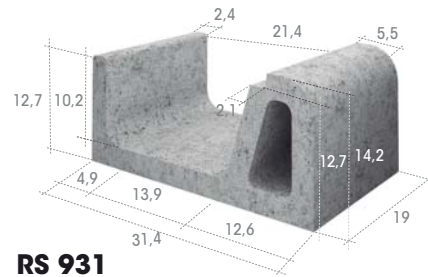

**RS 931**

Base

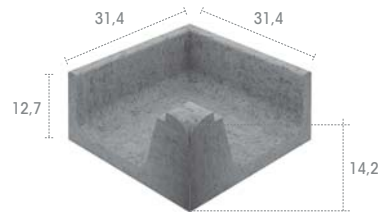

**RS 933**

Inside corner

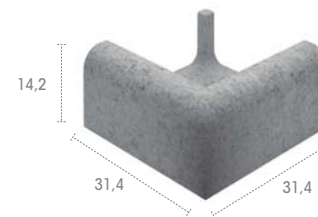

**RS 938**

Outside corner

## OVERFLOW POOL SYSTEM

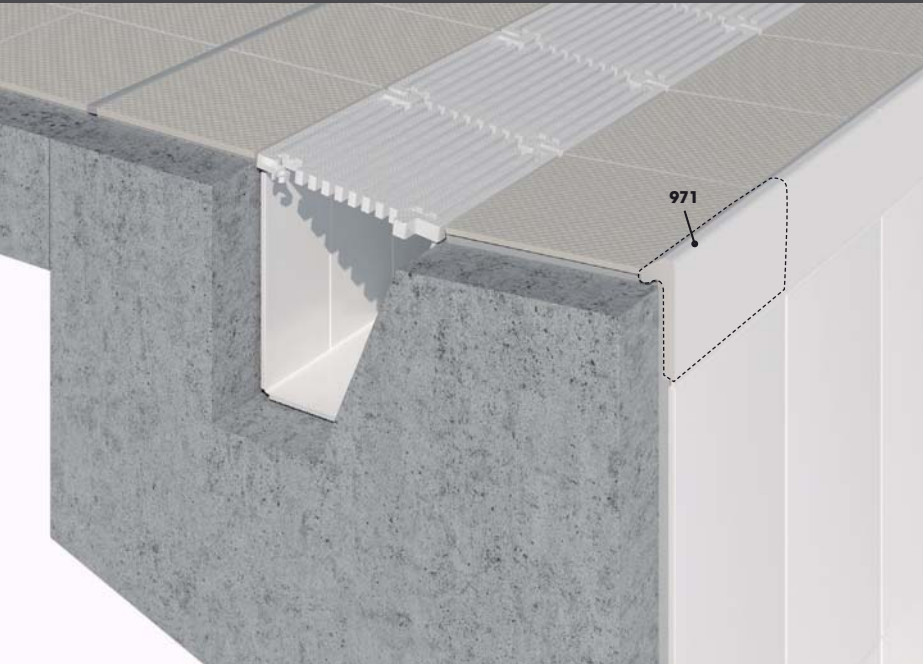

# Zurich System

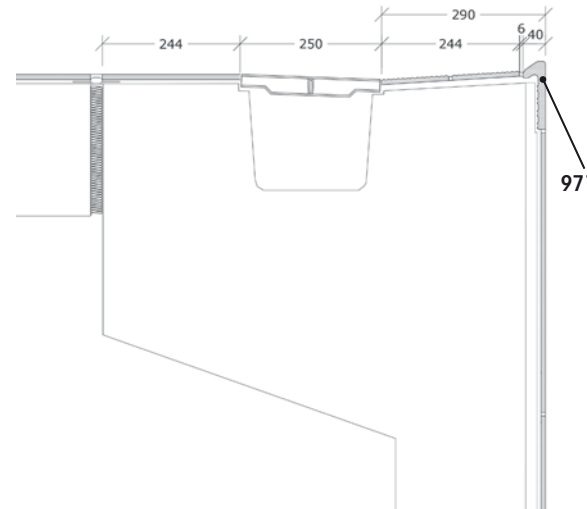

### Coping tiles and corners

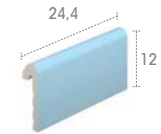

**971**  
anti-slip



## OVERFLOW POOL SYSTEM

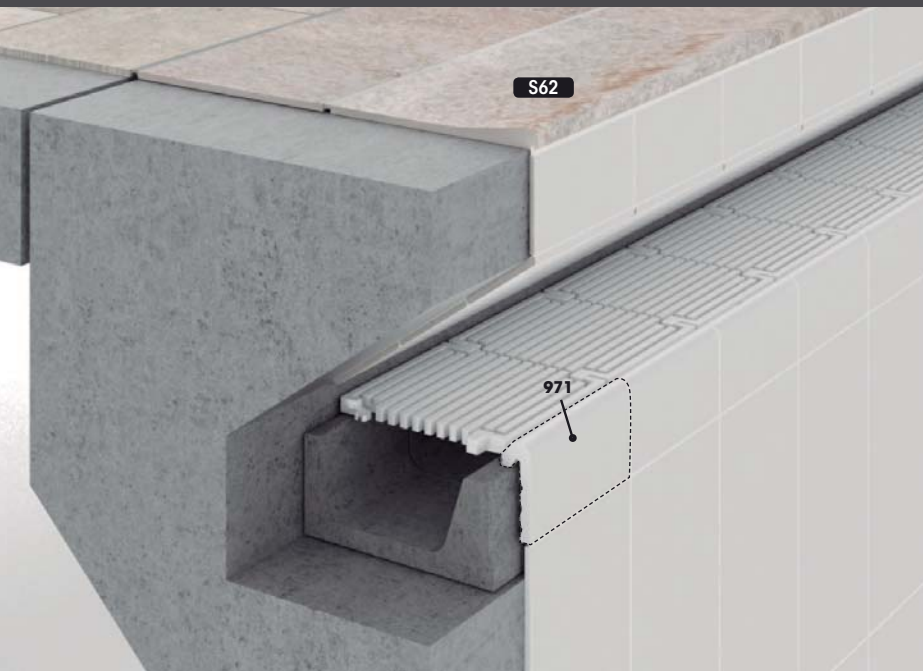

# Wiesbaden B System

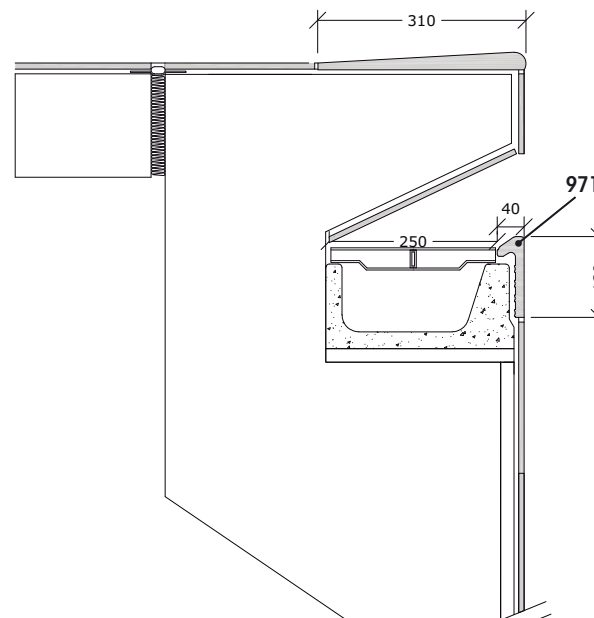

### Coping tiles and corners

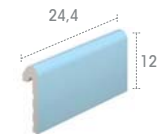

**971**  
anti-slip



## Half-round pieces

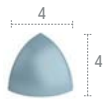
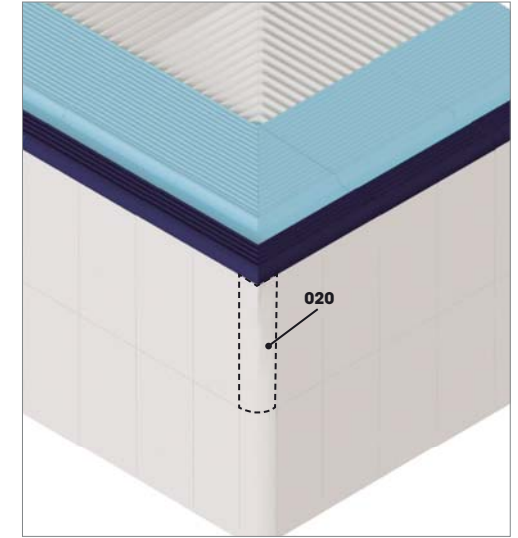
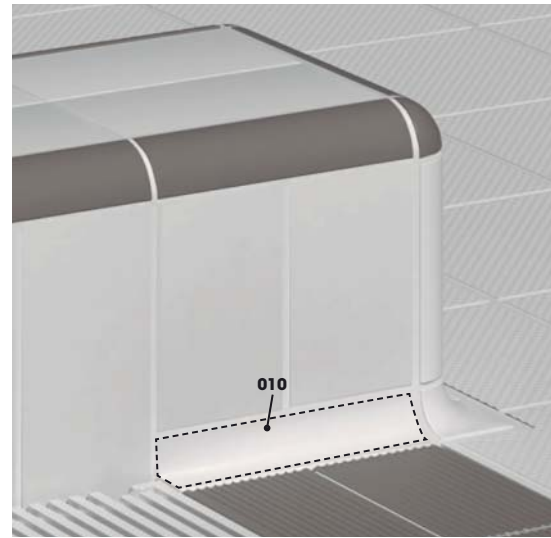
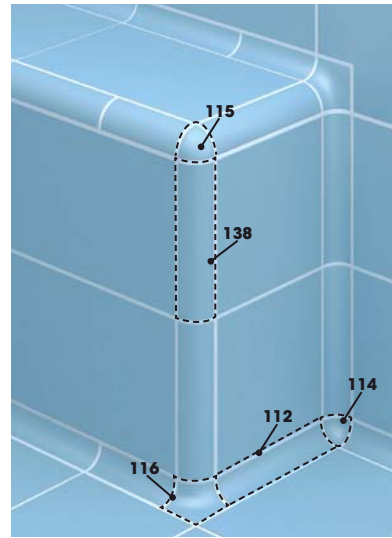
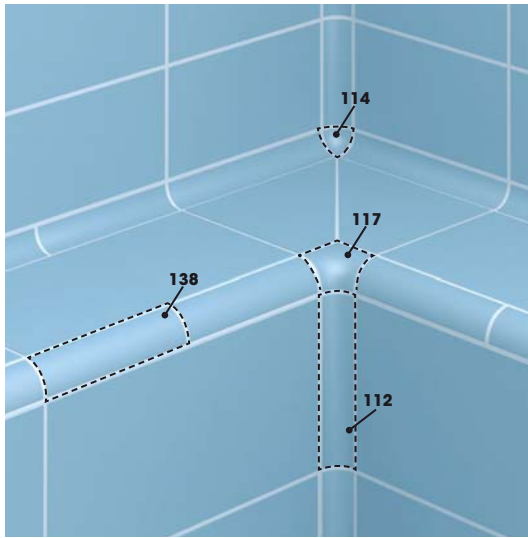

**115**

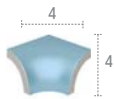

**117**

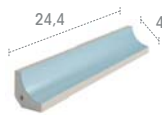

**112**

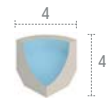

**114**

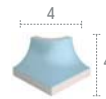

**116**

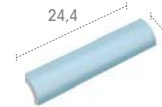

**138**

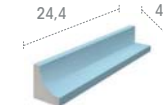

**010**



**020**

anti-slip



smooth



smooth



anti-slip



smooth



Grooved tiles

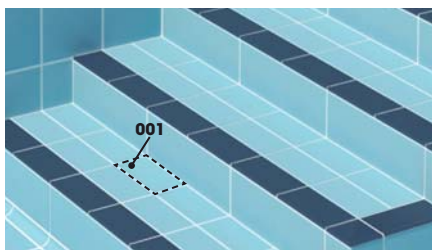
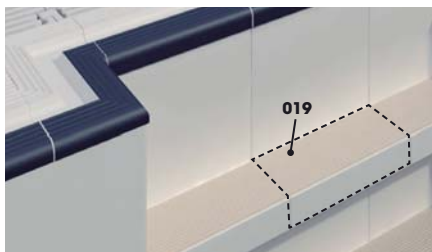

Bullnose

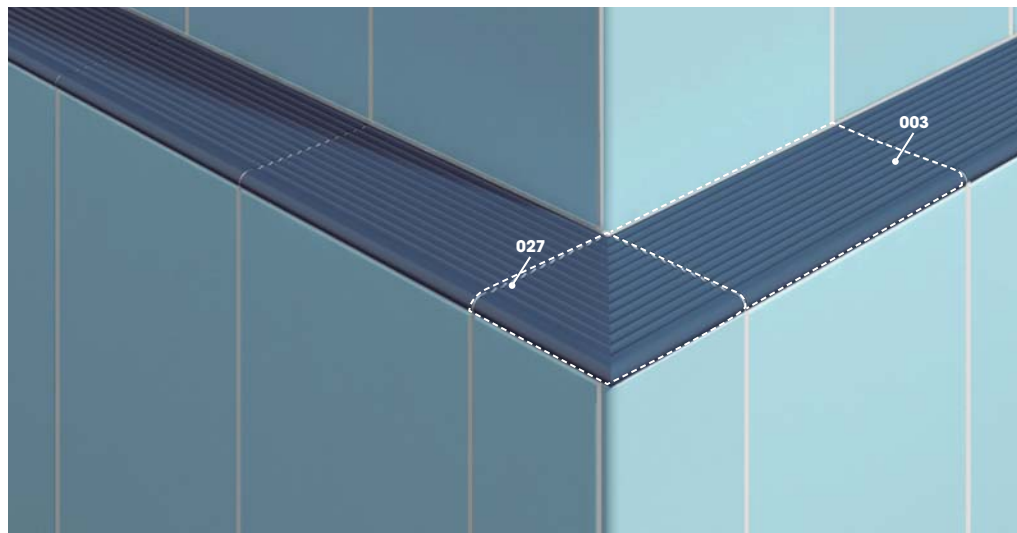

Depth tiles

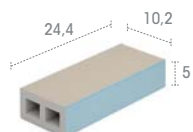

019

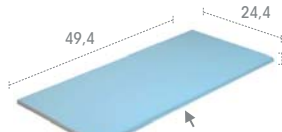

413

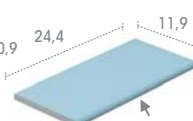

013

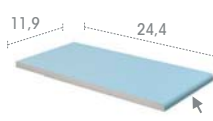

009

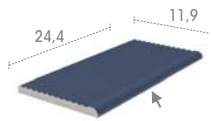

003



027

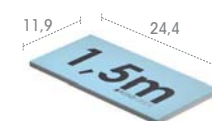

122 N9  
smooth / anti-slip

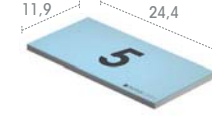

122 PO/122 P8  
smooth

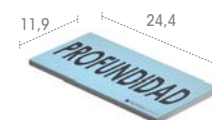

122 P9  
smooth / anti-slip

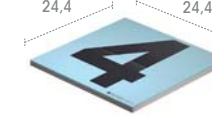

C01 / C08  
smooth

anti-slip

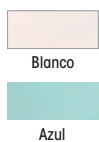

smooth



smooth / anti-slip



smooth / anti-slip

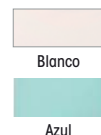

anti-slip



anti-slip



## Water bed and stairs

### Ergo

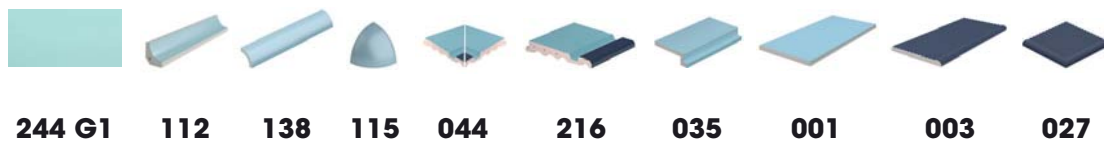
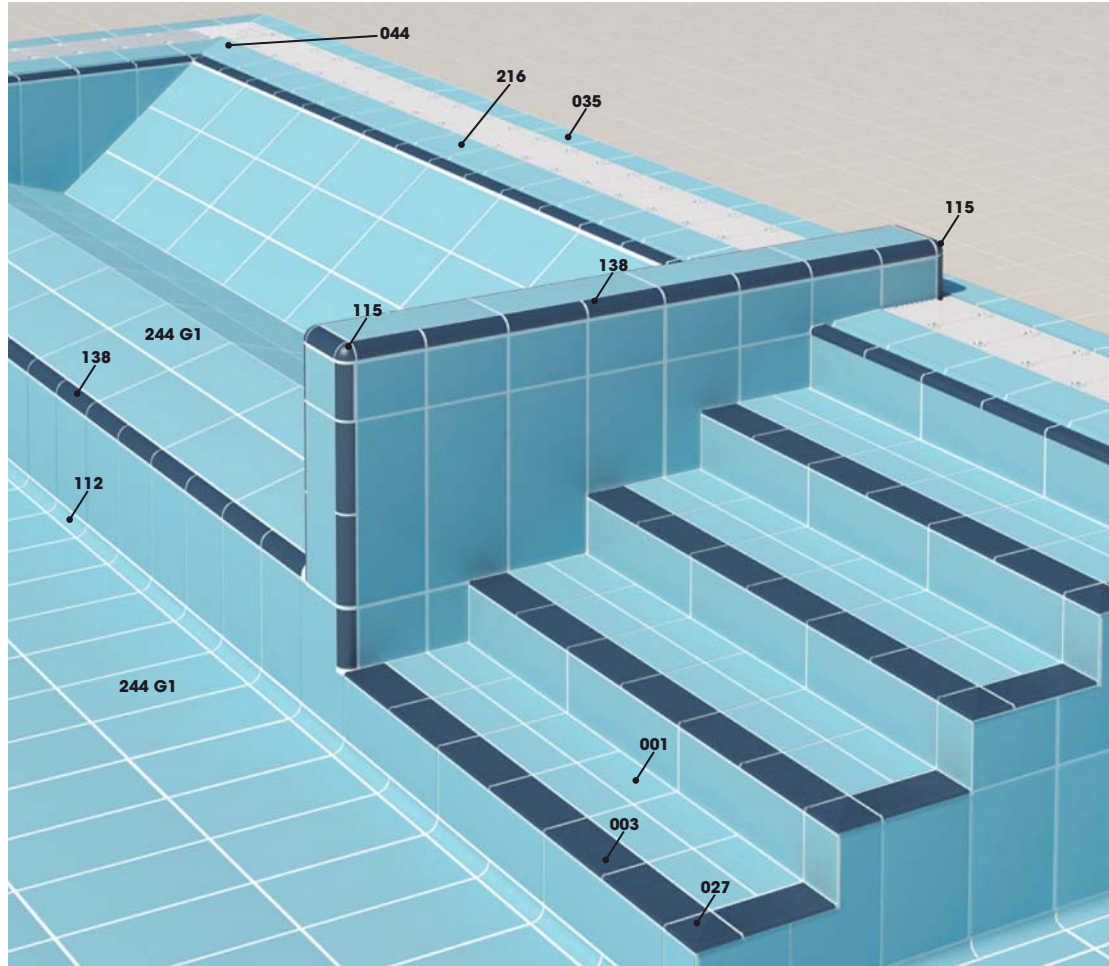

## Headwall for podiums and closed stairs

### Horyzon

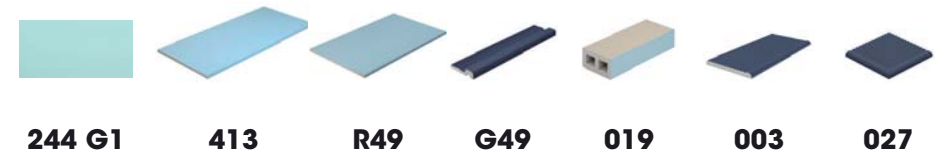
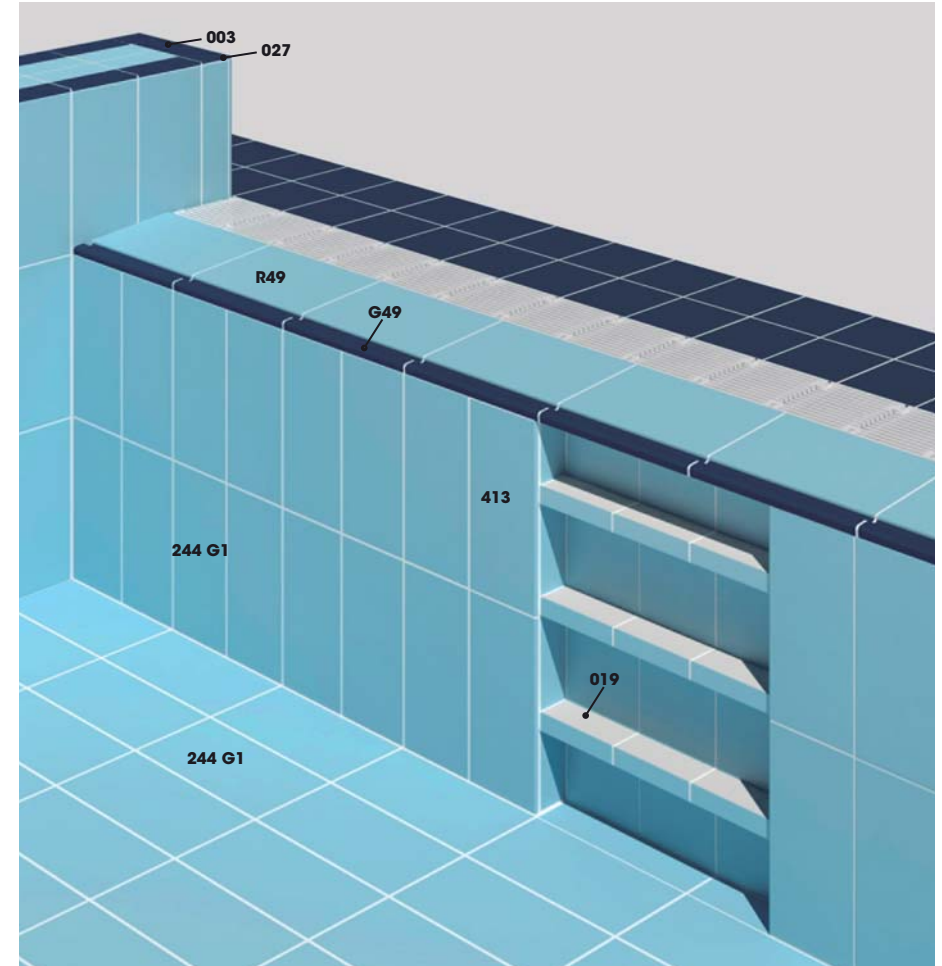



Headwall for podiums

Ergo

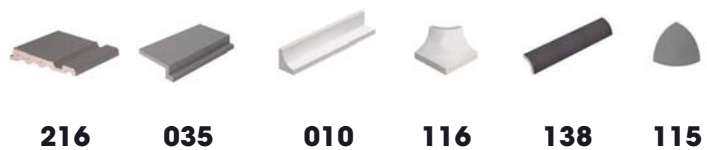
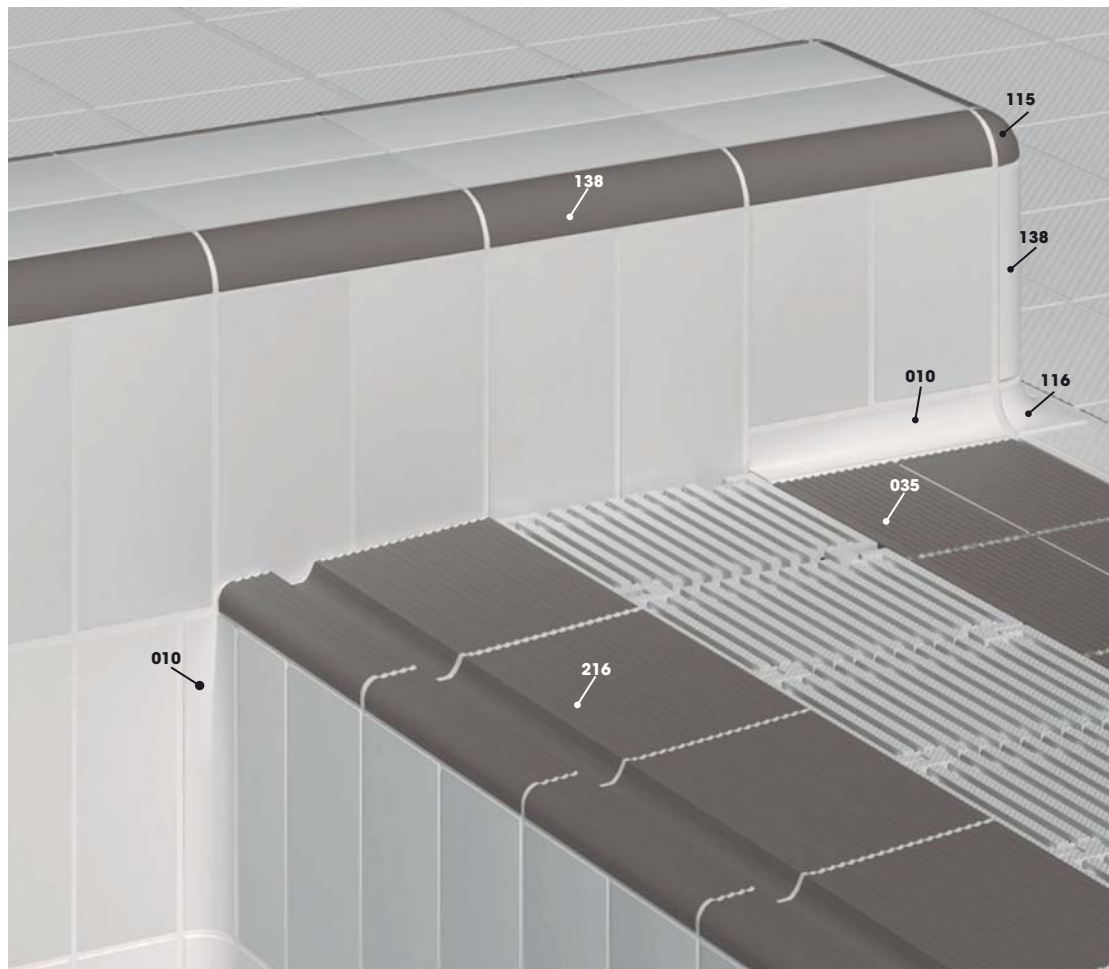

Bench

Wiesbaden

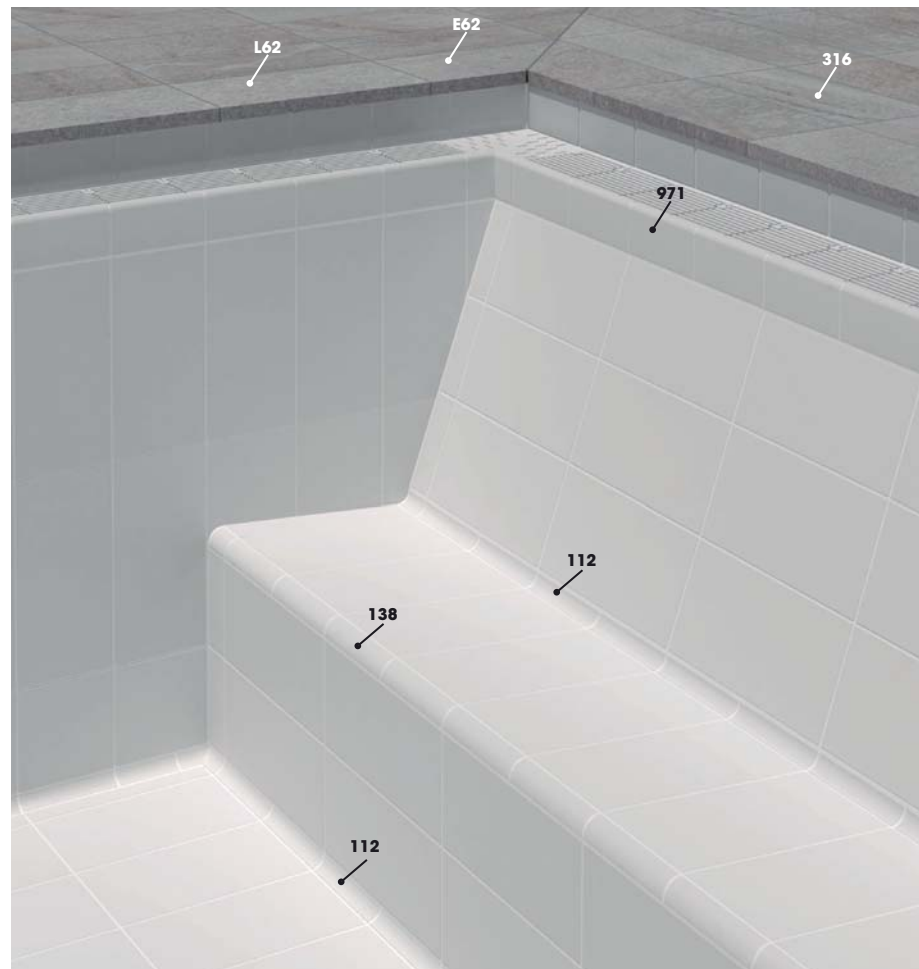

### Waterways

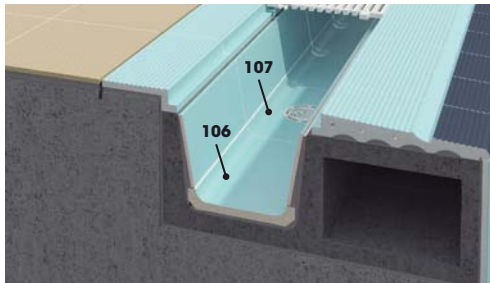
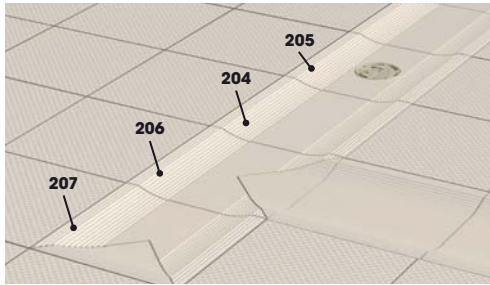

Finn Valley Leisure Center, Donegal, Ireland  
Blanco

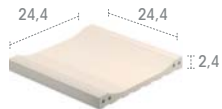

**204**  
anti-slip

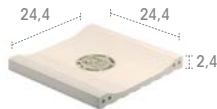

**205**  
anti-slip

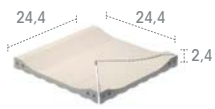

**206**  
anti-slip

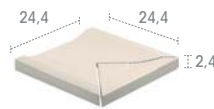

**207**  
anti-slip



Plomo



Indubeige



Complejo Deportivo Municipal La Granja, Navia, Vigo, Spain | Naos Arquitectura  
Aqua

# Indugres 100% Biostop Finish

## Half-round pieces

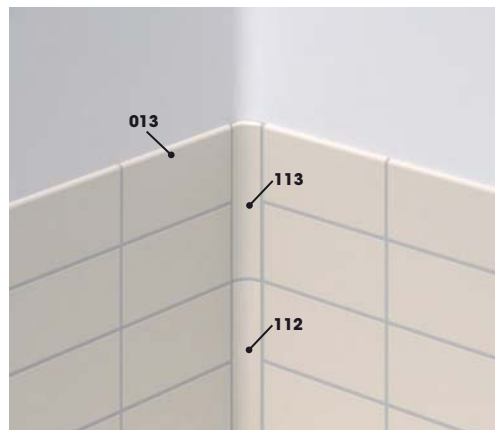
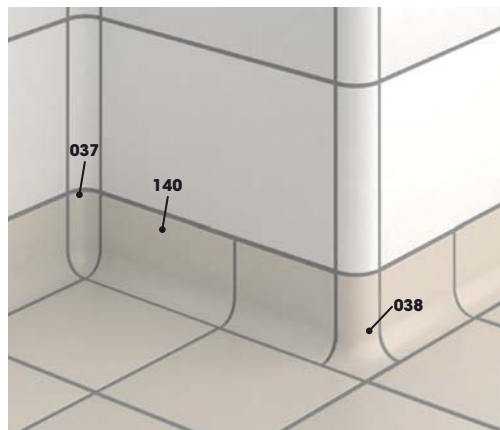

## Waterways

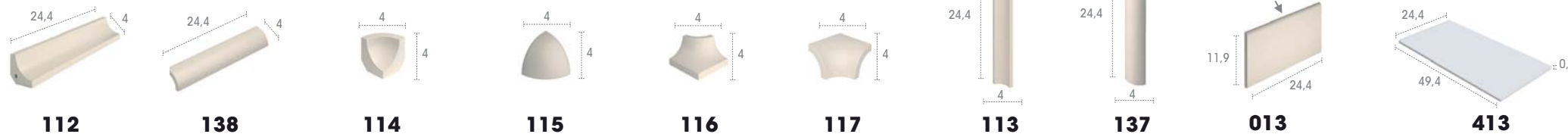
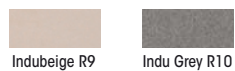
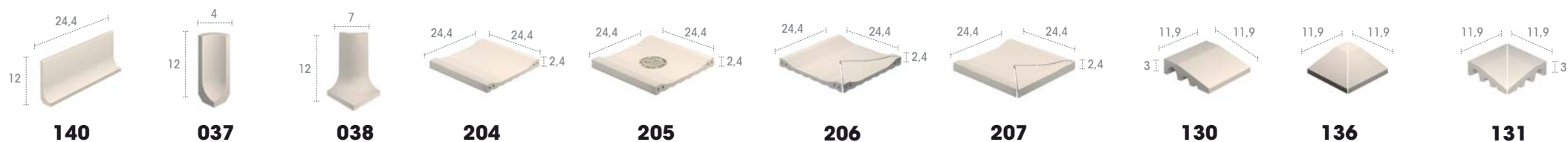
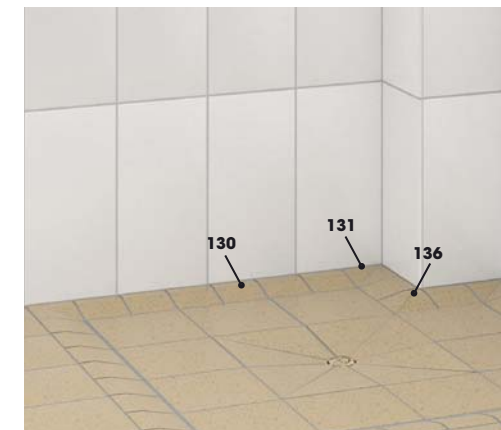
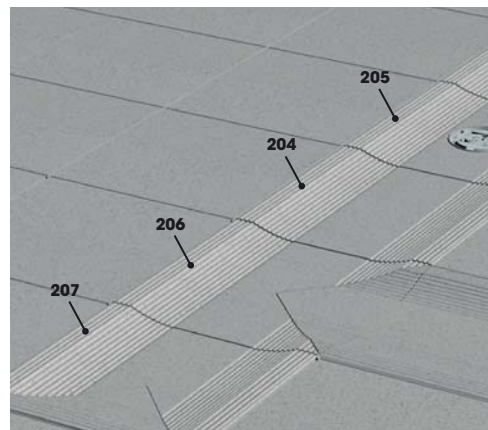

## GRATES

### GRATING

- 245 R2** 24,5 x 19,5 x 2,2
- 295 R2** 29,5 x 19,5 x 2,2
- 335 R2** 33,5 x 19,5 x 2,2



### 90° CORNER PLASTIC PIECE

- 195 E2** 19,5 x 19,5 x 2,2
- 245 E2** 24,5 x 24,5 x 2,2
- 295 E2** 29,5 x 29,5 x 2,2
- 335 E2** 33,5 x 33,5 x 2,2
- 195 E3** 20 x 20 x 3,5
- 245 E3** 25 x 25 x 3,5
- 295 E3** 30 x 30 x 3,5
- 335 E3** 34 x 34 x 3,5

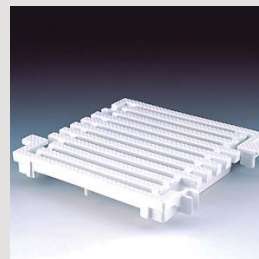

### LONGITUDINAL GRATE

- 195 L2** 19,5 x 20,6 x 2,4
- 245 L2** 24,5 x 20,6 x 2,4
- 295 L2** 29,5 x 20,6 x 2,4
- 345 L2** 34,5 x 20,6 x 2,4



### GRATING SUPPORT PROFILE (1)

- 243 PF** 2,4 x 3,7 x 200

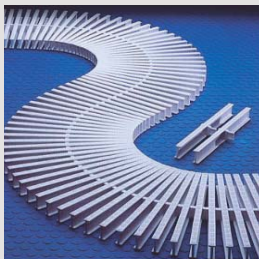

### MODULAR GRATE FOR BENDS

- 195 V2** 19,5 x 2,2
- 245 V2** 24,5 x 2,2
- 295 V2** 29,5 x 2,2
- 335 V2** 33,5 x 2,2
- 195 V3** 19,5 x 3,5
- 245 V3** 24,5 x 3,5
- 295 V3** 29,5 x 3,5
- 335 V3** 33,5 x 3,5



### END PIECE FOR LONGITUDINAL GRATING

- 195 T0** 19,5 x 2,4
- 245 T0** 24,5 x 2,4
- 295 T0** 29,5 x 2,4
- 345 T0** 34,5 x 2,4

### LONGITUDINAL GRATE

- 245 L2** 24,5 x 100 x 2,4



### MODULAR GRATE FOR BENDS

- 245 V2** 2,5 x 250 x 2,4



### GRATING (2)

- 245 R2** 24,5 x 250 x 2,4

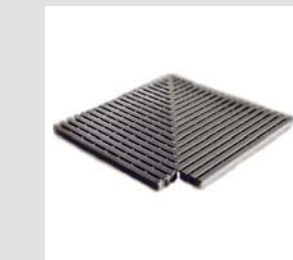

### 90° CORNER PLASTIC PIECE

- 245 E2** 24,5 x 24,5 x 2,4

## CORK FLOATS LINE

### CORK FLOATS LINE (3)

- ROMM2**  
25
- ROMM5**  
50



### SLOPING ANCHORAGE

- ANIH1**  
Ø43 Tube
- ANIH2**  
Ø48 Tube



### FLAT ANCHORAGE

- ANPH1**  
Ø43 Tube
- ANPH2**  
Ø48 Tube



### CORK FLOATS HOLDER

- SPCH1**  
Ø43 Anchorage



### ANCHOR CUP

- CAE00**  
Retractable anchor



### SCREW ANCHOR

- ANTH1**  
Ø43 Tube



(1) 2 units required to hold the grid

(2) Sold in units of 2'5 m

(3) Anchorages not included

(4) Stairs with customized porcelain stoneware steps

(5) Podium numbers not included

LADDERS



LADDER WITH HANDRAIL MODEL 1000

**MILX3**  
3 Steps  
**MILX4**  
4 Steps



MODEL SPLIT LADDERS

**PTDX3**  
3 Steps  
**PTDX4**  
4 Steps



LADDER WITH HANDRAIL ERGO MODEL

**EPEZ3**  
3 Steps  
**EPEZ4**  
4 Steps es



ASYMMETRIC LADDER

**SMA00**  
2 Handrail



EXTERNAL / INTERNAL HOLDER EXITS

**PAS00**  
043 Steel Inox

SIGNS



FALSE START SIGNALING FOR POLES (3)

**SS FH 1**  
Ø43 Poles  
**SS FH 2**  
Ø48 Poles  
**SS FFC**  
Polyester rope



SWIMMERS' START PODIUM (5)

**PDAH7**  
70 cm high - blue



SIGNAL FLAGS (3)

**BDNH1**  
Ø43 Poles  
**BDNH2**  
Ø48 Poles  
**BDNHBC**  
2 Strings and signal flags



LIFE PRESERVER

**SAL PL**  
Plastic  
**SAL LN**  
Canvas



HYDRAULIC ELEVATOR

**ELVML**  
Handrail 1000  
**ELV65**  
Handrail 650

SIGNS



LIFE PRESERVER SUPPORT

**SSV00**



LIFE PRESERVER STAND

**PSV00**

OTHER OPTIONS



POLYPROPYLENE ANCHORAGE

**ANEH 1**



PVC DRAINS

**990**



DRAIN SILENCER

**DS2**



PP HOMOPOLYMER

**EMB 00**

NOTE: Stainless steel complements aren't suitable for sea-water pools

Information

# Technical

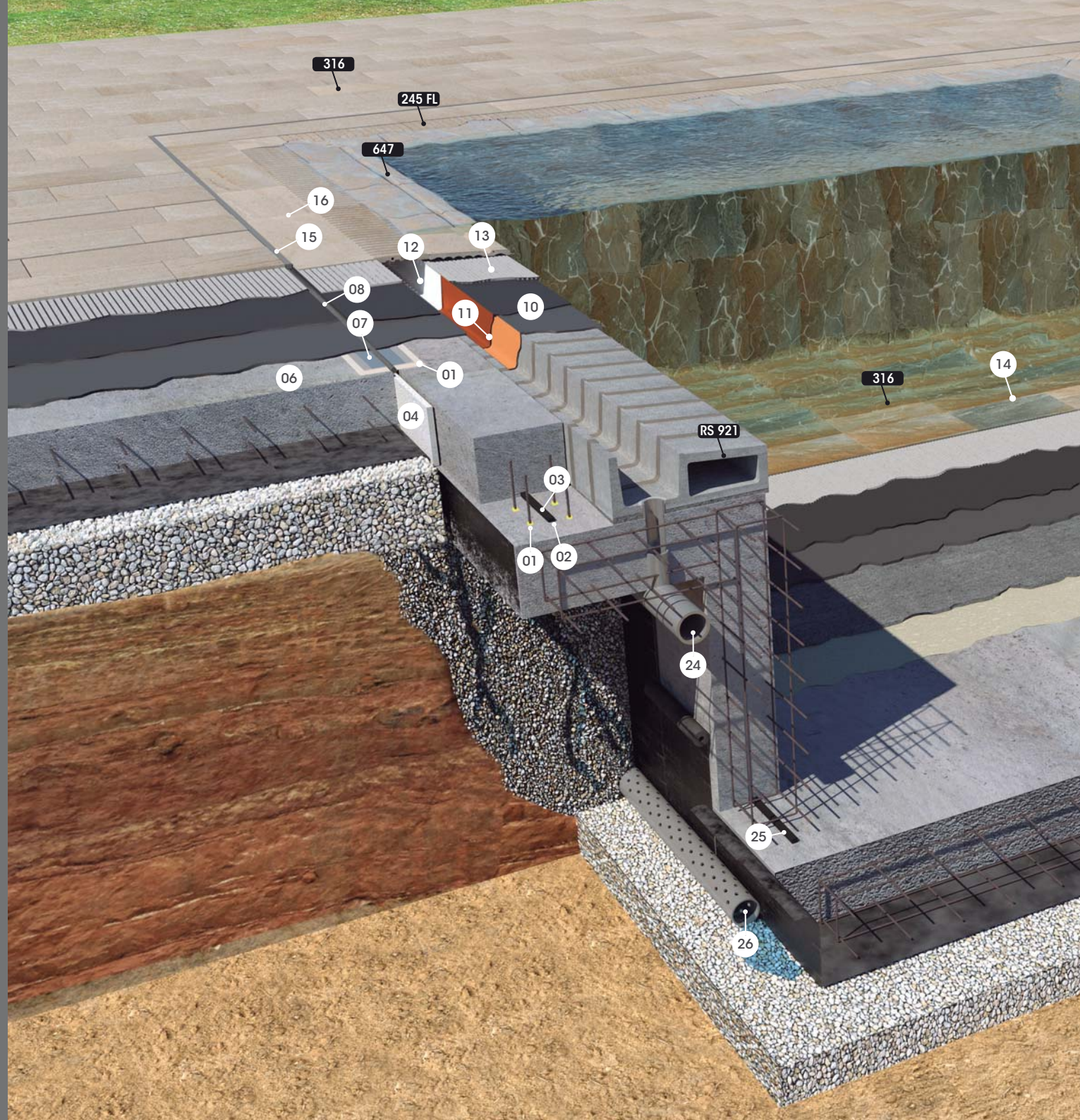

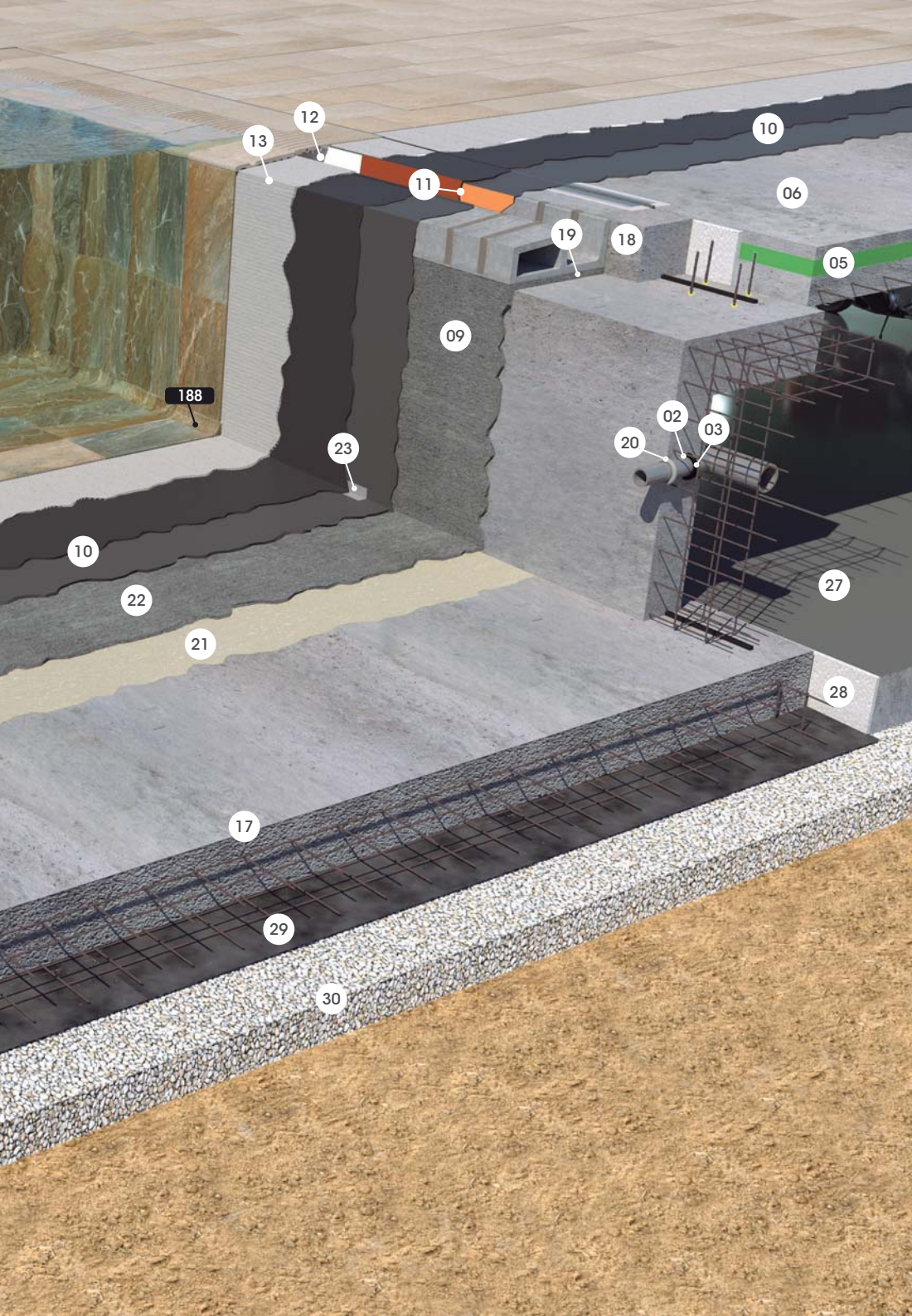

- 01 **EPOXICOL** Anchoring epoxy mortar
- 02 **MASTIC MS** Polyurethane Putty
- 03 **FUGA-STOP MINI 20 x 10 mm** Hydro-expansion joint
- 04 Expanded polystyrene
- 05 Extruded polystyrene
- 06 **PAVIFORT** Screed mortar
- 07 **FIX-TAPE 170 mm** Elastic and watertight expansion joint
- 08 **SELLALASTIC FOAM** Elastic joint filling cord
- 09 **FIX-REVOCO** Mortar for walls
- 10 **HIDROELASTIC** 1st and 2nd hand waterproofing layer
- 11 **HIDROFIX** 1st and 2nd hand of waterproof mortar
- 12 **EPOXICOLOR** Acid-resistant paint
- 13 **TECNOCOL FLEX** Highly adhesive for bonding ceramics
- 14 **CERPOXI** Acid-resistant epoxy mortar, 100% watertight
- 15 **SELLALASTIC** Elastic putty
- 16 **EUROCOLOR FLEX** Single-component coloured mortar
- 17 Concrete tank structure
- 18 Wall behind the Rosa Gres S9 blocks
- 19 Adhesive mortar of the pieces S9 improved with **PRIMFIX**
- 20 **IMPRIMACIÓN + SELLADOR 10** Watertight sealing
- 21 **PRIMFIX** Bonding bridge
- 22 **RECRECEM PRE-MIX** Screed mortar
- 23 **BANDA IMPERMEABLE** Elastic and watertight strip
- 24 Water collection pipe for overflow channels
- 25 **FUGA-STOP 25 x 20 mm** Hydro-expansion joint
- 26 Terrain drainage tube
- 27 Reinforced concrete of the parking
- 28 Expanded polystyrene in the expansion joints between base slabs
- 29 Phreatic sheet
- 30 Crushed gravel layer

## System 9, the prefabricated coping for overflow pool system patented by Rosa Gres

**System 9** consists in a prefabricated coping made of waterproof concrete blocks. Each piece functions as both a channel and a support for the ceramic. **System 9** improves the construction of deck level pools, both public and private.

### The advantages of System 9

#### MORE AGILITY

The installation process has been perfected to reduce time, labor, economic and energetic resources.

#### LESS DIFFICULTY

The pieces have been designed to optimize their placement and make the construction process easier.

#### MORE EFFICIENT FINISH

It improves the upper finish of the sprayed concrete wall, increasing the life of the building.

#### HIGHER PRECISION

Eliminates the deficiencies produced by the formwork.

#### EXCELLENT FINISH

The final result is a perfect water overflow, more hygiene, less need to use purification products and less water loss.

#### BETTER ESTHETIC OUTCOME

The pool's perimeter is more beautiful, rectilinear and homogenous.

#### MORE SUSTAINABLE

The building is more sustainable thanks to the reduction of energy and resources.

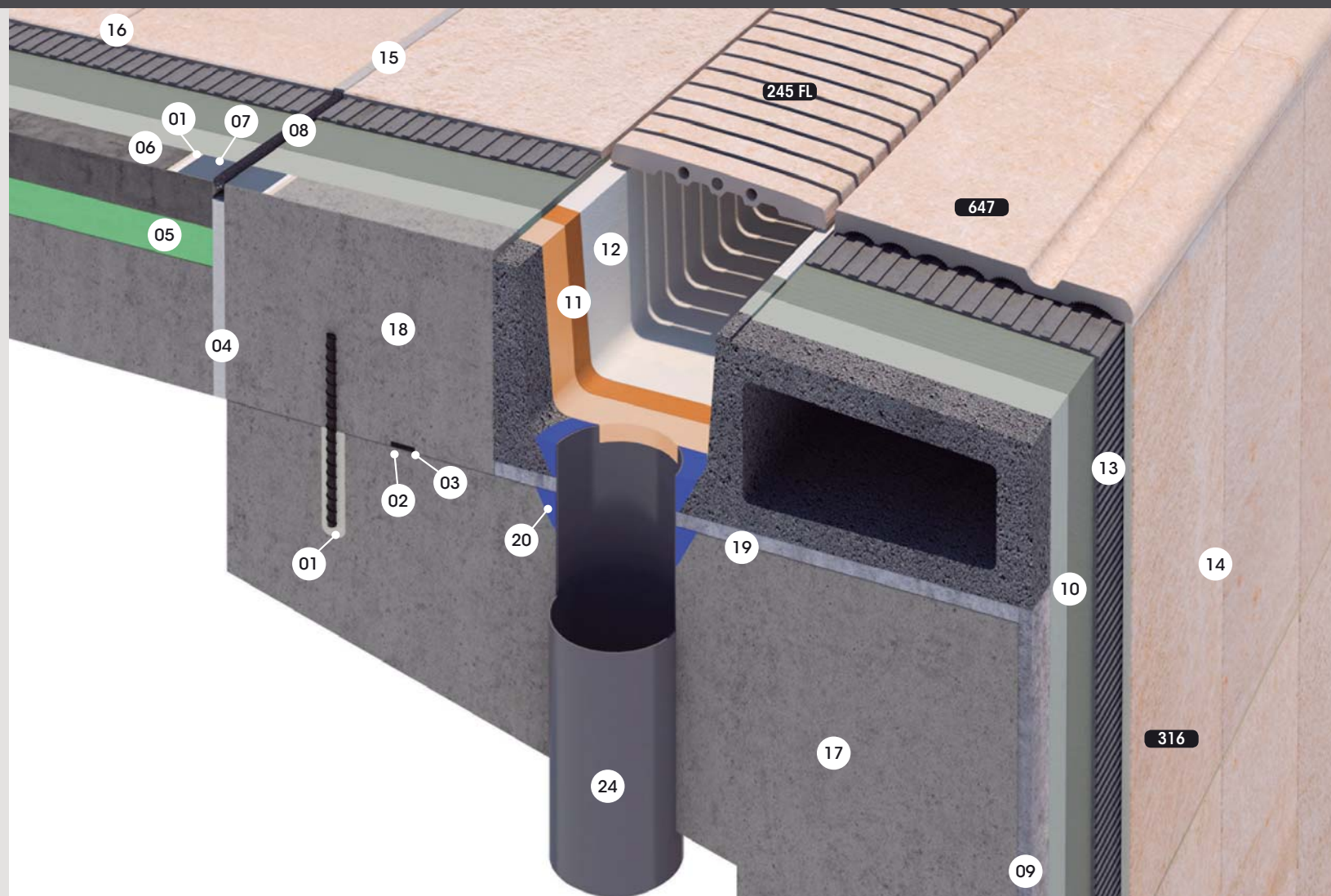

01 EPOXICOL

02 MASTIC MS

03 FUGA-STOP MINI 20 x 10 mm

04 Expanded polystyrene

05 Extruded polystyrene

06 PAVIFORT

07 FIX-TAPE 170 mm

08 SELLALASTIC FOAM

09 FIX-REVOCO

10 HIDROELASTIC

11 HIDROFIX

12 EPOXICOLOR

13 TECNOCOL FLEX

14 CERPOXI

15 SELLALASTIC

16 EUROCOLOR FLEX

17 Concrete structure of the tank

18 Wall behind the Rosa Gres S9 blocks

19 Improved adhesive mortar with Primifixo fix S9 pieces

20 IMPRIMACIÓN + SELLADOR 10 Watertight sealing

24 Water collection pipe for overflow channels





01

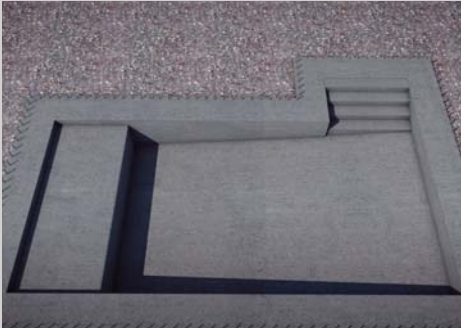

The concrete is cast, forming the walls, tank bottom and perimeter low wall, leaving a reception area in which to place the S9 block that will have the same measurements as the block.

02



To simplify the process of concreting, this may be done in two stages. First we prepare a flat reception area with some reinforced iron bars and we then place the hydro-expansive joint **FUGA STOP MINI** in between the reinforced bars. Then it is finished by filling the gap (after step 5). Glue the joint with **MASTIC MS**.

03

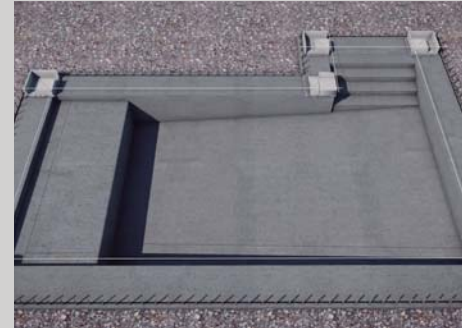

We start by positioning the pieces of the corners using a laser level. We place twine between them. Then we position the S9 blocks between corner and corner.

04



The concrete blocks are positioned with mortar to which the latex type additive **PRIMFIX** has been added with 1 part **PRIMFIX** to 2 parts water. **Note:** For salt water pools, consult our technical department.

05



It is also essential to place mortar in the joint between the blocks. Once the blocks have been positioned the back gap is filled with concrete.

06



Using the blocks as a guide, the mortar screed of the walls is performed with **FIX-REVOCO**, a quick-drying mortar of uniform quality.

07

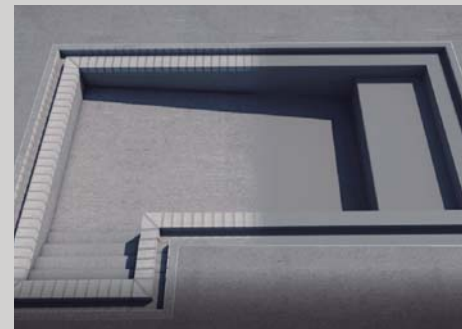

The waterproofing of the tank is carried out with **HIDROELASTIC** elastic waterproofing, on top of which the tiles will be placed. And the waterproofing of the channel is done using **HIDROFIX** waterproofing.

08



Use **TECNOCOL FLEX**, an adhesive cement type C2 TE S1, for adhering the porcelain stoneware on top of the waterproofing. Perform the grouting with **EUROCOLOR FLEX** or **CERPOXI**.



## 01 DIMENSIONS

When deciding on the final distance between the concrete walls, take into account the fact that the waterproofing, the screed, the cement glue and the ceramic tile are approximately 3.5 cm (1 1/7") thick at each of the walls. Therefore if the finished pool must be 25 cm, the distance between walls cannot be less than 25.07 m.

For competition pools, an additional 1.5 cm should be taken into account to place the touchpads. Therefore, if we are trying to standardise a 25 m pool, this should have a distance of 25.03 m between both ends.

**NOTE:** If using S9 blocks, plan enough space for them and the mortar.



## 02 WATERTIGHTNESS

The water tightness is **assured by the concrete tank**. Any waterproofing treatment is only an additional guarantee of watertightness. Therefore the concrete used must be waterproof.

One way of ensuring a pool is watertight is to use the expansive joint **FUGA-STOP** on the wall-floor, wall-wall and concrete joints before pouring the concrete. When **FUGA-STOP** comes into contact with the water, it reacts by expanding and containing any leaks.

A watertightness test must be carried out when the concrete tank is complete. The pool should then be filled and checked for leaks over a period of 2 or 3 weeks.



## 03 PREPARING THE SURFACES: SCREEDS

Eliminate any dust or oil residue from the concrete.

### To ensure the adhesion of the mortar:

Apply a bonding paste made of 1:1 **PRIMFIX** latex and Portland cement. Apply with a brush. This bond ensures adhesion between the concrete and the screed.

Use a screed mix that is specifically formulated to be used in swimming pools. The **FIX-REVOCO** mortar for walls and the **RECRECEM PRE-MIX** mortar for floors are formulations containing clean sands, devoid of expansive clays, slags, etc. They are very easy to use with everyday tools and have the added advantage of setting quickly. After 24 hours we can perform the next step.



## 04 WATERPROOFING AND LAYING THE CERAMIC TILES

Concrete undergoes structural movements due to pressure, compression and shrinkage throughout its life cycle. These small movements can compromise the watertightness of pools. One simple, inexpensive way of applying a second watertight seal is by waterproofing the walls, floor, overflow outlet and channel using the elastic mortar **HIDROELASTIC**. After a couple of days, lay the ceramic tiles with **TECNOCOL FLEX**, a C2 TE S1 cement, suitable for applying on waterproof layers. Use a 10 mm notched trowel. We recommend using the double application technique.

If owing to budget constraints it is not possible to apply an extra waterproofing, set the tiles directly on the screed mortar. Once this mortar is cured and dry, set the tiles using **FIXAGRES FLEX** - C2 TE cement. Use a 10 mm notched trowel. We recommend using the double application technique.



05

### DISTRIBUTION OF POOL COMPONENTS

#### BEFORE INSTALLATION: MARKING THE POOL

1. Place the special corner pieces, according to the type of perimeter edge chosen, in the four corners.
2. Draw marks every linear metre around the whole perimeter, using the corner pieces as a starting point.
3. A piece can be placed every linear metre to serve as a guide.
4. Mark coloured vertical lines down the side of the walls (blue marking paint or similar).
5. Crisscross the lines on the tank bottom. The tank will therefore form a grid pattern and serve as a perfect guide for laying the ceramic pieces.
6. If necessary, mark the lines for the lanes on both the walls and the bottom of the pool.
7. Place the 119 x 244 parts in a ratio of 4 pieces per linear metre lengthways and 8 pieces across. The 244 x 494 ones are placed in a ratio of 2 pieces per linear metre lengthways and 4 pieces across. In both cases the joint between pieces will be approximately 6 mm.



06

### STARTING THE TILING

1. Begin tiling the walls following the coloured lines previously marked.
2. Cross-pieces can be used on the verticals, inserting them between the pieces as shown in the photograph.
3. Once all the walls have been tiled, place the parts on the bottom of the tank.
4. Cross-pieces do not need to be used for the flooring as final adjustment of the pieces can be carried out by hand, always following the lines.



07

### WATERPROOF GROUT

Another way of improving the watertightness of the tank is to use **CERPOXI**, a fully watertight, flexible and acid-proof mortar.

The **EUROCOLOR FLEX** coloured mortar is a very good alternative. It is resistant to weak acids and has a residual absorption value of just 2%.

**IMPORTANT:** Wait for 5-7 days before filling with water. In salt water chlorination or salt-water pools, use **CERPOXI**.



08

### EXPANSION JOINTS

The structural joints of the pool, when there are any, have to be respected. Place expansion joints every 25 square meters and/or 5 linear meters at most.

For the sealing, use **SELLALASTIC FOAM** as grouting and **SELLASTIC** elastic filler as the final sealing. Wait for 5-7 days before filling pool.

## S9 ERGO / S9 FINNISH - HORYZON / S9 PRESTIGE

There are public, municipal, campsite, hotel and residential pools that require an overhaul to correct flaws and to adapt them to new safety regulations. That is why renovating old skimmer pools to turn them into infinity pools - much more hygienic and safe - has now become so important.

Yet how can this be done quickly, efficiently and economically? By using System 9 blocks from Rosa Gres. With System 9, the overflow channel can be made very quickly. Here is how to do this step by step.

### Project:

Renovating a skimmer pool to turn it into an infinity pool with Ergo S9 blocks. Ridaura Camp site

(Llagostera - Spain)



### 1 PREPARATION OF THE SURFACE

We remove the old coping. We dig a trench around the tank in which to pass the pipes of the overflow system. We place the reinforced bars fixed with epoxy resin or chemical wadding.

Place the hydro-expansive joint **FUGA-STOP**, ensuring that there will be at least 7 cm of concrete all around it.

### 2 MAKE THE BASE

We set up irons that will reinforce the bracket, leaving the reinforced bars for the back gap. We make the base with concrete in order to be able to place the S9 blocks. Along with the reinforced bars of the back gap we will once again place the concrete joint **FUGA-STOP MINI**.

In some cases, when we find there is a sufficiently wide wall, the base will not need to be built, although it is always necessary to make the back gap.

### 3 PLACING THE S9 BLOCKS

See details on how to place the S9 blocks on page 96.

### 4 FILLING IN THE BACK GAP

Fill the back gap with concrete, and, if necessary, screed the walls. In the picture you can see how straight the overflowing channel should be, which will facilitate laying the tiles at the edge of the pool.

### RAISING THE BOTTOM OF THE TANK

For comfort, safety and water saving, swimming pools are now shallower than before, so it would probably be a good idea to raise the bottom of the tank when renovating an old pool. We can also pass the pipes of the new fittings through this screeding.

### 5 WATERPROOFING

We waterproof the blocks and the tank with the elastic cementitious waterproofing **HIDROELASTIC**. The inside of the overflow channel is waterproofed with **HIDROFIX** waterproofing.

When the surface is still wet (and we cannot wait for it to dry completely) we will apply a first coat of **HIDROFIX**, reinforcing it with the fiberglass mesh **NET-HIDRO 80**. When it dries we will continue with the 2 coats of **HIDROELASTIC**.

### 6 LAYING THE CERAMIC TILES

We will lay the tiles with **TECNOCOL FLEX**, a glue cement of the type C2 T S1 suitable for gluing porcelain tiles on waterproofing. Grout using **CERPOXI** or **PROFESSIONAL PX**.

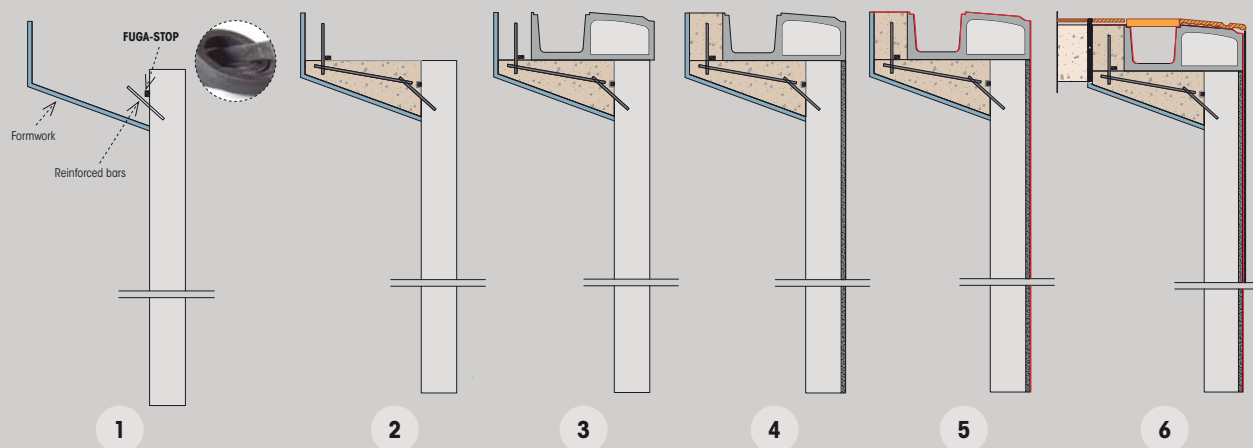

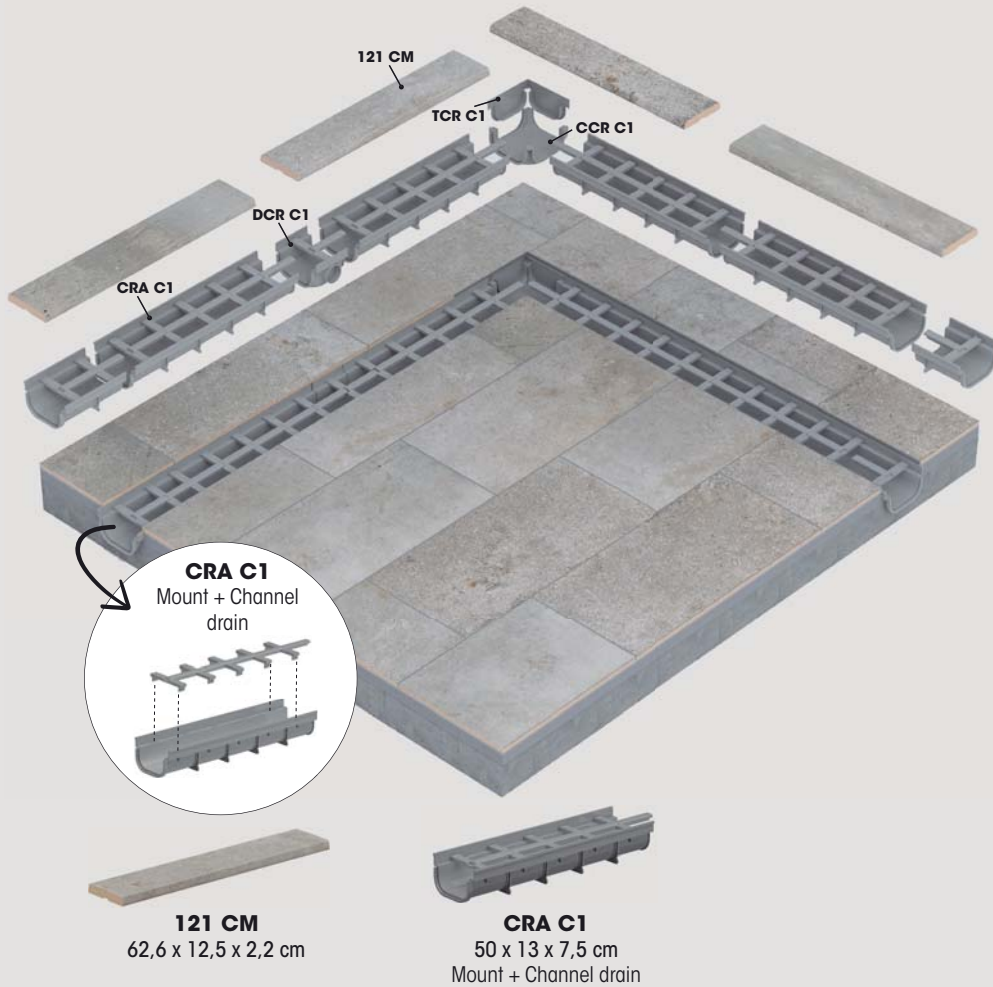

**121 CM**  
62,6 x 12,5 x 2,2 cm

**CRA C1**  
50 x 13 x 7,5 cm  
Mount + Channel drain



**CCR C1**  
PVC Junction



**TCR C1**  
PVC Ø 40 Terminal

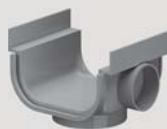

**DCR C1**  
PVC Drain  
Ø 40: Side  
Ø 75: Base

**PLACEMENT**

1. The channel drain installation must be performed on a resistant and preferably waterproof base.

2. Place the PVC channels making sure they are level and leaving the top of the finish at the required height based on the placement diagram, taking into account the thickness of the chosen ceramic (9 or 10 mm). Attach the PVC sections (Ref. CRA C1) to one another using the 50-cm connective sections with tongue-and-groove joints, which can optionally be glued with PVC glue. Place the trim pieces for connections to drains (Ref. DCR), intersections (Ref. CCR) and terminals (Ref. TCR) as needed. Place the mounts for the ceramic grid inside the channel in order to secure the channel and make sure it is firm and well aligned.

3. Pour in the concrete along the perimeter until reaching the height required to start placing the chosen ceramic paving. We recommend a minimum slant of 1.5-2%. We also recommend waterproofing the concrete once in place.

4. Set the ceramic paving using the right adhesive cement or glue by laying the ceramic on the upper part of the plastic grid and evening the inner side to guarantee it is level with the ceramic grid.

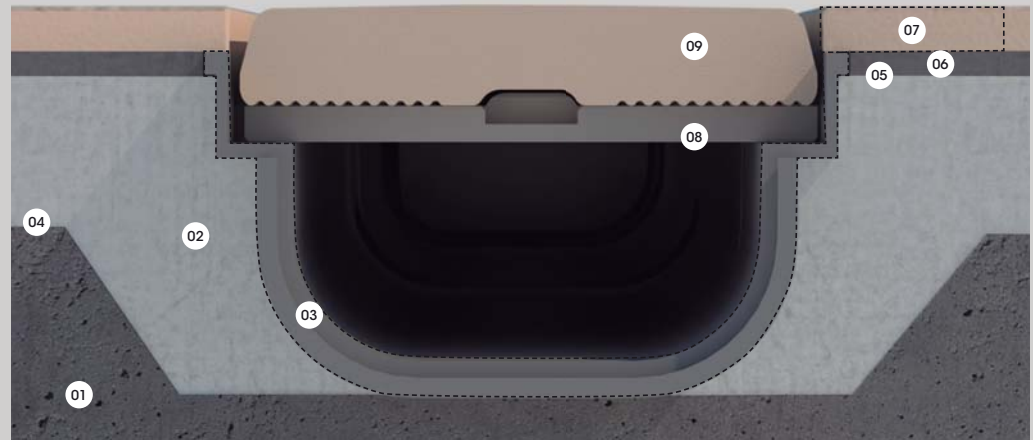

01 Sturdy base (Concrete deck)

02 Mortar layer  
(E.g., **PAVIFORT**)

03 PVC Channel (Ref. CRA C1)

04 Base waterproofing (E.g., **HIDROFACIL**)

05 Waterproofing / Protective layer on the mortar layer  
(E.g., **HIDROFACIL**)

06 Glue - Adhesive cement for porcelain  
(E.g., **TECNOCOL FLEX**)

07 Rosa Gres porcelain stoneware (9-10 mm)

08 Ceramic mounts inside the channel (Ref. SCR C1)

09 Rosa Gres porcelain stoneware grid (Ref. 121 CM)



## SYSTEM 10: THE SOLUTION FOR BUILDING THE PERFECT CONCRETE PREFAB POOL



**PREFABRICATED  
CONSTRUCTION**



**100%  
WATERTIGHT**



**TEMPERATURE  
REMAINS STABLE**



**MAXIMUM  
DURABILITY**



**EXACT PRICE  
QUOTE**



**FASTER, FEWER  
RESOURCES AND  
LESS WASTE**



**SUITABLE FOR  
EXTREME CLIMATES**



**ZERO MAINTENANCE  
POOLS**



### THE REVAMPED SYSTEM 10 WITH 6 NEW COLORS



#### SYSTEM ERGO / UNIQUE POOLS COLORS

##### Edge pieces

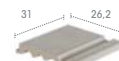

**416**  
Pietro White



**416**  
Stela Golden



**416**  
Serena Bianco



**416**  
Serena Ocrá



**416**  
Mistery Grey



**416**  
Mistery Blue Stone

##### Trim pieces

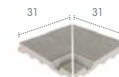

**044**

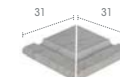

**042**



**176**

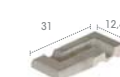

**175**



**478**

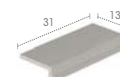

**435**

##### Available colors



Pietro White



Stela Golden



Serena Bianco



Serena Ocrá



Mistery Grey



Mistery Blue Stone



**COMPETITION POOLS  
ACCORDING TO THE  
SPECIFICATIONS OF THE  
INTERNATIONAL SWIMMING  
FEDERATION**

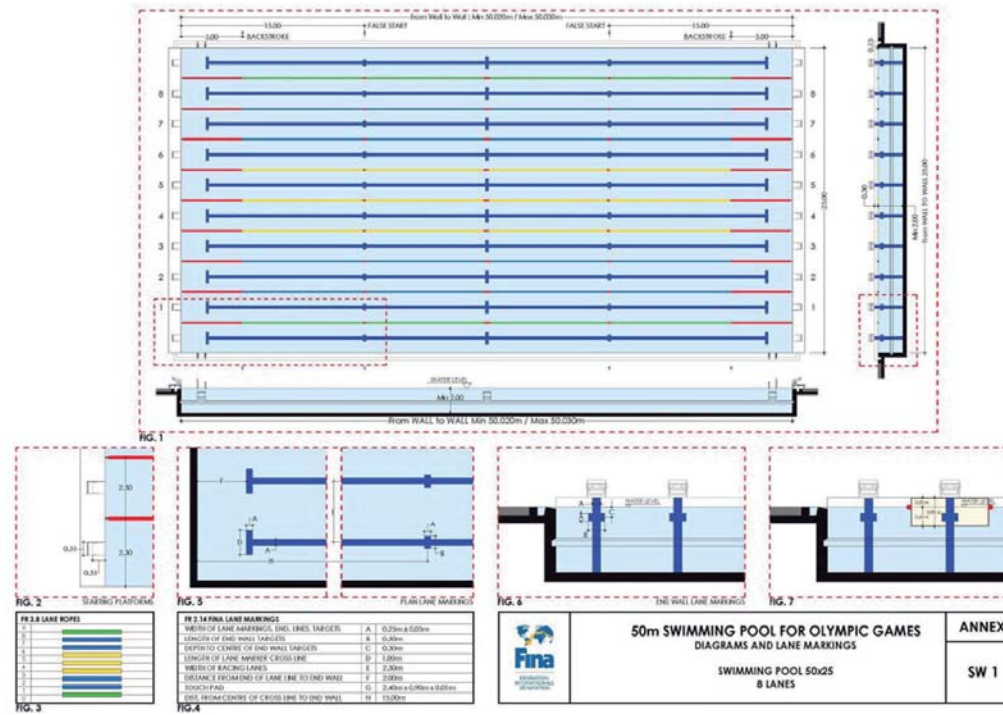

**REALIZATION OF  
PROJECTS WITH REVIT  
FOR INTEGRATION WITH  
BIM.  
VISUALIZATIONS AND  
VIRTUAL REALITY FOR  
PROJECT DESIGN.**

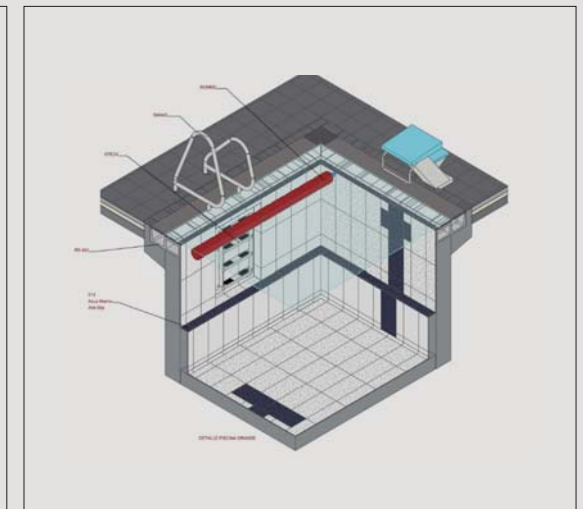
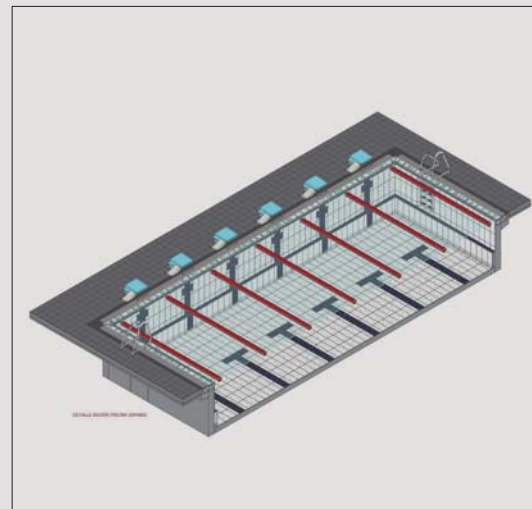
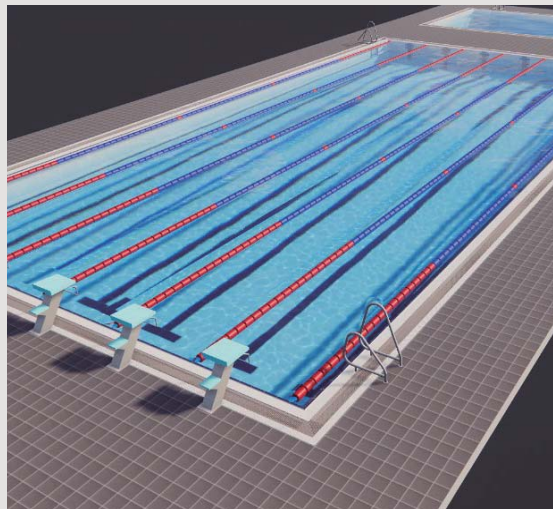

### INTENSIVE CLEANING AFTER FINISHING THE WORK

While carrying out the work, the flooring becomes dirty due to its anti-slip properties. It is therefore essential to perform a "intensive cleaning" after finishing the work.

#### STEP BY STEP

1. During the installation, we should remove all traces of adhesive material and grouting. It is imperative to clean them instantly with a damp sponge and not allow them to dry. The rough texture of the anti-slip finish will make it notably more difficult to remove once dry.

2. We should sweep the entire surface and collect all of the construction debris to prevent the formation of "smears" during future cleanups. We should check that the joints have hardened completely.

3. We should ensure there are no traces of dry grout or fixing material. In some cases, this cannot be seen as the grouting colour is very similar to that of the ceramic tiles.

If we find that there are still remnants of work materials, and the joints have hardened completely, we should follow these guidelines:

Prepare the **GRESNET** dilution in water. We should start with a very low concentration. We should apply the dilution over a small area, using a hard bristle brush. Whilst wet and without waiting for it to dry, we should rinse with plenty of water to remove all traces.

For remnants made from epoxy compounds: we should apply the **EPOXI CLEANER** stripper. We should proceed to mechanically remove the dirt after at least one hour has passed. Finally we rinse with plenty of clean water.

It is important to be careful not to damage the joint, as in this case the material from the joint would further dirty the surface of the tiles.

### MAINTENANCE AND DAILY CLEANING

To remove normal daily dirt, the best solution is to use a good cleaning product combined with correct action.

#### OUR ADVICE

##### 1. Daily cleaning

Simply use clean water and the alkaline-based detergent **FIX-SABÓ**. Avoid the use of detergents that leave a surface layer of wax or grease, since that would enhance the adherence of dirt. They could also adversely affect the anti-slip resistance of the floor.

##### 2. Stubborn spots and conflictive areas

We recommend using high pressure cleaning equipment or cleaning machines with rotating cylindrical brushes. Hot water and brushing aggressively are also recommendable.

##### 3. Always with clean water

For the best results, we recommend changing the cleaning water approximately every 15 m<sup>2</sup> of floor. If we continue using the water, the dirt in suspension will be deposited onto the following the tiles you clean.

##### 4. Water alkalinity

In geographical areas where the water is hard, we recommend installing a water softener. If we do not have one, to prevent lime deposits collect the water immediately after cleaning.





Rosa Gres ceramic tiles are resistant to stains in accordance with the ISO 10545-14 standards. Tests indicate that they correspond at least to class 4, which means stains can be easily removed.

## HOW TO TREAT STAINS

### Stains and anti-slip floors

Anti-slip floors have rough surfaces and need special attention when a staining element penetrates their surface roughness. It must be removed by using the appropriate technique for what it is made of. First, we should try to dissolve the stain. Later, we should remove it by any mechanical means necessary.

### Difficult stains

Stains that are especially difficult are those caused by carbon particles (black-colored grouts, black paints, graphite pencils and the like). It can only be removed by mechanical means.

### Identifying the nature of the stain

It is very important to identify which element has caused a stain. The stain can be removed if we use the right product; it is not advisable to use products at random. It is very useful to perform a cleaning test on a small area to check its action. After using one cleaning product and before using another, we must ensure that all traces of the former have been removed.

### Attention

When we use a chemical product, we should follow the instructions included in the safety sheet or operating instructions provided by the manufacturer. We recommend wearing gloves and goggles in all cases and to ventilate the area being treated if possible.

## STAIN CLEANING CHART

TYPE OF STAIN	CLEANING AGENT		
	GENTLE ACTION	VIGOROUS ACTION	VERY VIGOROUS ACTION
Cement, limescale and limescale residue	Diluted organic acids (vinegar)	Acid-based anti-lime detergent (Viakal®) Acid-based detergent (diluted Gresnet®) Diluted acidic product (diluted hydrochloric acid)	Undiluted acidic product (hydrochloric acid) Acid-based detergent (Gresnet®, Gresnet Plus®) Powerful descaling agent (PHZERO®)
Saltpeter or saline efflorescences	Diluted organic acids (vinegar)	Acid-based anti-lime detergent (Viakal®) Acid-based detergent (diluted Gresnet®) Diluted acidic product (diluted hydrochloric acid)	Undiluted acidic product (hydrochloric acid) Acid-based detergent (undiluted Gresnet®) Powerful descaling agent (PHZERO®)
Dirt or humidity in the joints	Oxidizing agent (Bleach)	Specific product for joints (Cillit Bang for dirt and humidity stains®)	Specific product for joints (FUGANET®)
Oxide deposits and rust stains	Acid-based detergent (Gresnet®)	Acidic product (Phosphoric acid) Diluted acidic product (diluted hydrochloric acid)	Undiluted hydrochloric acid Specific product for oxides (NO RUST®)
Tobacco	Acid-based detergent (Gresnet®)	Acidic product (Phosphoric acid) Diluted acidic product (diluted hydrochloric acid)	Undiluted hydrochloric acid
Vegetable oil and animal fat	Alkaline-based detergent (ammonia) Baking soda in water Degreaser (FIX-SABÓ®)	Solvent (Acetone) Caustic soda solution	Specific solvent (trichloroethylene or similar) Caustic soda
Beer, wine, coffee, tea, juice, Coca-Cola, ice cream	Alkaline-based detergent (ammonia) Oxidizing agent (Bleach) Degreaser (FIX-SABÓ®)	Solvent (alcohol, acetone)	Caustic soda
Paint residues, graffiti	Solvent (Acetone)	Specific solvent (turpentine)	Other specific solvents (NOPAINT STAR®, FIX-GRAF STONE®)
Rubber or tire residue	Solvents (acetone, alcohol)	Specific solvent (trichloroethylene or similar)	Other specific solvents (CLEANER PRO®, FIX-GRAF STONE®)
Nail polish	Solvent (Acetone)	Specific solvents (NOPAINT STAR®, FIX-GRAF STONE®)	
Candle wax residue	Solvent (ether, propanol)	Specific solvent (ZEROSIL®)	
Adhesive tape, glue, bubble gum or tree resin residue	Solvent (ether, propanol)	Specific solvent (ZEROSIL®)	
Silicone, acrylic filler or polyurethane foam residue	Solvent (ether, propanol)	Specific solvent for silicone (ZEROSIL®)	
Tree leaves, vegetable stains and animal excrement residue	Detergents with bleach (Estrella® floor cleaning product)	Oxidizing agent (Bleach)	
Iodine- and chromium-based compounds	Oxidizing agent (hydrogen peroxide)	Oxidizing agent (Bleach)	
Blood	Oxidizing agent (hydrogen peroxide)	Oxidizing agent (Bleach)	
Ink, marker or merbromin	Oxidizing agent (Bleach)	Solvent (alcohol, acetone)	Specific solvent (FIX-GRAF STONE®)
Food coloring	Oxidizing agent (Bleach)	Solvent (alcohol, acetone)	Specific solvent (SR95®)
Tar or bitumen	Oxidizing agent (Bleach)	Solvent (alcohol, acetone)	Solvent (trichloroethylene or similar)
Epoxy joint residue	Specific products (Epoxinet® during application Epoxicleaner® or CR10® for dry residues)	Specific products (Epoxinet® during application Epoxicleaner® or CR10® for dry residues)	

### PENDULUM METHOD

The test involves swinging a friction pendulum with a rubber skate on the end over the surface to be tested. The skate skims the surface along a determined distance (125 mm). Depending on the surface texture, the pendulum brakes to a greater or lesser degree. The test result indicates how much the skate's speed decreased, as measured on a calibrated scale.

UNE 41901			
	Rd < 15		CLASS 0
	15 < Rd	< 35	CLASS 1
	35 < Rd	< 45	CLASS 2
	Rd > 45		CLASS 3

### DIN STANDARD

These German test methods are intended for floorings that present a risk of being covered in slippery substances, both for people wearing footwear (DIN 51130) or who are barefoot (DIN 51097).

### STANDARD FOR FOOTWEAR

This test is performed on a device in which the person carrying out the test walks on an inclined slope which varies in angle, wearing footwear with standardised soles. The surface is covered with oil. The test seeks to find the angle of inclination of the slope with which they can still walk safely without slipping.

DIN 51130	
	R10 > 10° - 19°
	R11 > 19° - 27°

### STANDARD FOR BARE FEET

This test is performed on a device in which the person carrying out the test walks on an inclined slope which varies in angle. The surface is covered with the tiles to be tested and is continually covered with a soap solution. The test seeks to find the angle of inclination of the slope with which they can still walk safely without slipping.

DIN 51097	
	CLASS A ≥12°
	CLASS B ≥18°
	CLASS C ≥24°

### ANTI-SLIP COEFFICIENTS

		ANTI-SLIP COEFFICIENTS									
		UNE 41901			DIN 51130 XP P-05-010			DIN 51097 XP P-05-010		ANSI A137.1	
		Class 1	Class 2	Class 3	R9 / PC6	R10 / PC10	R11 / PC20	Class B / PN18	Class C / PN 24	> 0.42	
Unique pools	<b>trésor</b>	anti-slip			●		●			●	
	<b>stela</b>	smooth	●			●					
		anti-slip			●			●		●	
	<b>pietro</b>	anti-slip			●			●		●	
	<b>serena</b>	anti-slip			●			●		●	
	<b>alma</b>	smooth	●			●					●
anti-slip				●			●		●	●	
<b>mistery</b>	smooth	●			●						
	anti-slip			●			●		●	●	
Sport pools	<b>aqua</b>	pastilla anti-slip Tank			●				●		
	<b>mosaic</b>	anti-slip			●				●		
	<b>Indugres</b>	Indubeige R10		●			●		●		●
		Indu Grey R10		●			●		●		
		Indubeige R11			●			●	●		

## ROSA GRES RECOMMENDS

### INTERIOR FLOORING



PUBLIC AND PRIVATE USE



PROFESSIONAL KITCHENS / STAIRS / SLOPES > 6 %

### TERRACES



PROFESSIONAL KITCHENS / STAIRS / SLOPES > 6 %

### POOL DECKS



PROFESSIONAL KITCHENS / STAIRS / SLOPES > 6 %

### CHANGING ROOMS



SHOWER AND WET AREA



DRY AREA

THE FINAL ANTI-SLIP PERFORMANCE OF THE FLOORING IS REGULATED BY THE OFFICIAL REGULATIONS THAT APPLY TO EACH PROJECT.

**Base pieces:**

Group B1a pressed porcelain tiles

**Trim pieces:**

Group A1a extruded porcelain tiles

**Minimum joint (Field tiles)**

A 2 mm joint is needed. A minimum joint of 3 mm is recommended for the following formats: 48,8 x 48,8 cm and 48,8 x 97,9 cm. When it's necessary to modulate field tiles with trim pieces, the joint should be 6 mm (except for 48,8 x 97,9 cm format)

\* **Biostop (tiles and grout) complies with the JIS Z 280: 2000 Antimicrobial efficiency regulation**

TESTING REGULATIONS	REGULATION EN 14411	Unique Pools	Sport Pools		
		Trésor / Stela Pietro / Serena Alma / Mistery	Aqua	Indugres	Mosaic

**DIMENSIONS AND SURFACE QUALITY**

ISO 10545-2	Dimensions and surface quality	Required	Guaranteed	Guaranteed	Guaranteed	Guaranteed
-------------	--------------------------------	----------	------------	------------	------------	------------

**PHYSICAL PROPERTIES**

ISO 10545-3	Water absorption	Grupo A1a E < 0,5 %	Grupo B1a E < 0,5 %	E < 0,5 %	E < 0,5 %	E < 0,5 %	E < 0,5 %
ISO 10545-4	Flexural strength	Grupo A1a > 28 N/mm <sup>2</sup>	Grupo A1a > 35 N/mm <sup>2</sup>	> 40 N/mm <sup>2</sup>	> 40 N/mm <sup>2</sup>	> 40 N/mm <sup>2</sup>	> 40 N/mm <sup>2</sup>
ISO 10545-6	Resistance to deep abrasion	< 175 mm <sup>3</sup>	-	-	-	< 175 mm <sup>3</sup>	< 175 mm <sup>3</sup>
ISO 10545-9	Thermal shock resistance	Required	Guaranteed	Guaranteed	Guaranteed	Guaranteed	Guaranteed
ISO 10545-12	Frost resistance	Required	Guaranteed	Guaranteed	Guaranteed	Guaranteed	Guaranteed

**CHEMICAL PROPERTIES**

ISO 10545-13	Chemical resistance (1)	Min. Clase B	A / LA / HA	A / LA / HA	A / LA / HA	A / LA / HA
ISO 10545-14	Stain resistance	Min. Clase 3	Guaranteed	Guaranteed	Guaranteed	Guaranteed

(1) Except hydrofluoric acid and its components



Back cover: **Eau Thermale Avène l'Hôtel** | Architect, Isa Arnau, Territori 24 Arquitectura



### **Rosa Gres, SLU**

#### **Central office**

Ctra. Sant Cugat, km. 3  
08290 Cerdanyola, Barcelona, Spain  
Tel. + 34 93 586 30 60  
Ventas: + 34 93 586 37 00  
Export Sales: + 34 93 586 37 02  
info@rosagres.com  
www.rosagres.com

### **Rosa Gres France, SARL**

64140 Lons, France  
Tel. + 33 04 11 92 00 30  
contact@rosagres.com  
administration@rosagres.com  
www.rosagres.com/fr

### **Factory**

Pol. Ind. Mas Vell  
Ramón Sugrañes, 1  
43144 Vallmoll, Tarragona, Spain



 @rosagres  @rosagres  @rosagrescompany  @rosagres  @rosagresvideo

October 2021